

Technical documentation
Last changed on: 06.09.2019

CPS series

Built-in or System Capable Compact High Voltage Module

- Versions from 500 V – 30 kV
- patented resonance converter technology
- available as metal-box or 3U MMC version
- combinable in a multichannel THQ AC/DC HV power supply
- INHIBIT
- low ripple and noise, low EMI
- hardware limits for voltage and current



Document history

Version	Date	Major changes
2.3	06.09.2019	improved description
2.2	27.06.2019	Error correction
2.1	11.06.2019	Error correction Improved description
2.0	21.09.2017 13.06.2018	Relayouted documentation Improved documentation

Disclaimer / Copyright

Copyright © 2019 by iseg Spezialelektronik GmbH / Germany. All Rights Reserved.

This document is under copyright of iseg Spezialelektronik GmbH, Germany. It is forbidden to copy, extract parts, duplicate for any kind of publication without a written permission of iseg Spezialelektronik GmbH. This information has been prepared for assisting operation and maintenance personnel to enable efficient use.

The information in this manual is subject to change without notice. We take no responsibility for any mistake in the document. We reserve the right to make changes in the product design without reservation and without notification to the users. We decline all responsibility for damages and injuries caused by an improper use of the device.

1 General description

CPS modules are highly stable analog controlled High Voltage Power supplies. They are available as compact metal box or system capable in 3U Eurocassette standard. Modules of the CPS series can be used as standalone DC/DC converters and also be combined to a multichannel AC/DC supply in a THQ series or integrated in a modular MMC system. The output voltage is controllable with an analog interface with either a potentiometer (internal reference voltage) or an input analog control voltage. To protect the connected load the modules are equipped with INHIBIT, current and voltage limits.

Customized versions can be produced on request.

2 Technical Data

SPECIFICATIONS	CPS	CPS 3U	CPSmini
Out voltage V_{nom}	500 V – 30 kV		1 – 6 kV
Polarity	Factory fixed, positive or negative		
Ripple and noise ($f > 10$ Hz) ⁽¹⁾	$< 10\text{kV: typ. } < 2 \cdot 10^{-5} \cdot V_{nom}$ $\geq 10\text{ kV: typ. } < 5 \cdot 10^{-5} \cdot V_{nom}$		$< 2.5 \cdot 10^{-6} \cdot V_{nom}$
Stability [ΔV_{out} vs. ΔV_{in}] ⁽¹⁾	$< 1 \cdot 10^{-4} \cdot V_{nom}$		$< 5 \cdot 10^{-5} \cdot V_{nom}$
Stability - [ΔV_{out} vs. ΔR_{load}] ⁽¹⁾	$< 2 \cdot 10^{-4} \cdot V_{nom}$		
Temperatur coefficient	100 ppm / K		50 ppm / K
Supply voltage V_{in}	22.8 – 25.2V		
Supply current I_{in} at $V_{out} = 0$ at $V_{out} = V_{nom}$ / with load	< 50 mA < 800 mA		< 25 mA < 450 mA
Set / Monitor voltage	0 - 5 V opt. 0 - 10 V		0 - 5 V
Adjustment accuracy	± 1 %		
Voltage ramp up/down	$0.25 \cdot V_{nom} / s$		
Protection	Overload and short circuit protected, INHIBIT, V/I-limit (ATTENTION: there is only one short circuit or arc per second allowed!)		
System / Remote connector	D-Sub 9	H15	Pin
HV connector	HV-cable	500V – 7kV → SHV 10kV – 30kV → G11, G21, G31	Pin
Case	metal box <u>moulded</u>	3U cassette (MMC capable)	metal box moulded
Dimensions – L/W/H	500V – 7kV → 155/75/40 mm ³ 10kV – 15kV → 185/75/40 mm ³ 20kV – 30kV → 185/95/40mm ³	500V – 7kV → 8HP / 40.64 mm ³ 10kV – 30kV → 12HP / 61.0 mm ³	120/40/25 mm ³
Operating temperature	0 – 50 °C		0 – 40 °C
Storage temperature	-20 – 60 °C		
Humidity	max. 70 %		
Notes:	¹⁾ Specifications for stability, ripple and noise are guaranteed in the range $2\% \cdot V_{nom} < V_{out} \leq V_{nom}$; $I_{set} \geq 4\% I_{nom}$ for CPS/ CPS 3U $I_{set} \geq 1\% I_{nom}$ for CPS mini		

Table 1: Technical data: Specifications

CONFIGURATIONS CPS							
	V _{nom}	I _{nom}	Standard Ripple (mV _{p-p})	Internal Capacitance nominal (nF)	Damping Resistor (kOhm)	Discharge Resistor (MOhm)	Item Code
CPx 05 206 24 y	500 V	20 mA	10	620	0.05	55	CP005206x24500000000
CPx 10 106 24 y	1 kV	10 mA	20	250	0.1	55	CP010106x24500000000
CPx 15 805 24 y	1.5 kV	8 mA	30	120	0.1	55	CP015805x24500000000
CPx 20 605 24 y	2 kV	6 mA	40	65	0.1	55	CP020605x24500000000
CPx 30 405 24 y	3 kV	4 mA	60	42	0.1	55	CP030405x24500000000
CPx 40 305 24 y	4 kV	3 mA	80	30	0.2	500	CP040305x24500000000
CPx 50 205 24 y	5 kV	2 mA	100	30	0.7	500	CP050205x24500000000
CPx 70 155 24 y	7 kV	1.5 mA	150	5	0.7	500	CP070155x24500000000
CPx 100 105 24 y	10 kV	1 mA	500	14	13	660	CP100105x24500000000
CPx 150 604 24 y	15 kV	0.6 mA	750	3.5	13	660	CP150604x24500000000
CPx 200 504 24 y	20 kV	0.5 mA	1000	3	13	660	CP200504x24500000000
CPx 300 304 24 y	30 kV	0.3 mA	1500	1.7	20	660	CP300304x24500000000
CONFIGURATIONS CPSmini							
CPx 10 805 24 5 M	1 kV	8 mA	10	110	0.22	55	CM010805x24500000000
CPx 20 405 24 5 M	2 kV	4 mA	10	45	1	55	CM020405x24500000000
CPx 30 255 24 5 M	3 kV	2.5 mA	10	33	1.5	55	CM030255x24500000000
CPx 40 205 24 5 M	4 kV	2 mA	10	24	1.5	200	CM040205x24500000000
CPx 60 135 24 5 M	6 kV	1.3 mA	20	18	5.1	200	CM060135x24500000000

Table 2 Technical data: Configurations

ORDER INFO	INFO	EXAMPLE
POLARITY	Positive: x = p Negative x = n	CP p 05 206 24 5
Set / monitor voltage	0 – 5 V (standard): y=5 0 – 10 V (optional): y=10	CPp 05 206 24 10
3UC	3U , Height unit based on the 19-inch standard housing, MMC capable version	

Table 3: Technical data: Options and order information

3 Dimensional drawings

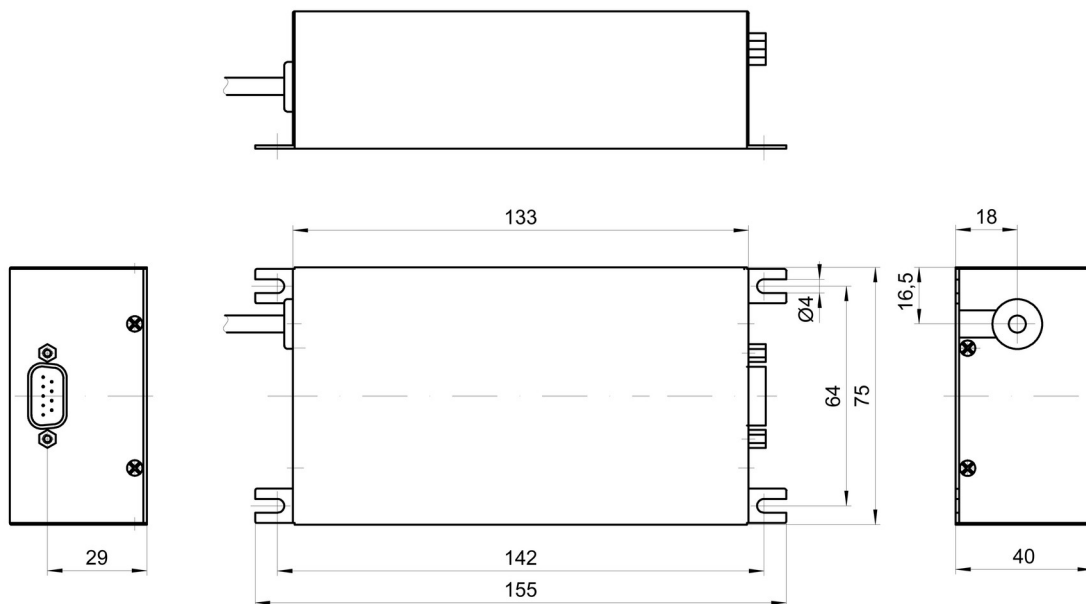

Figure 1: dimensional drawing CPS <7kV

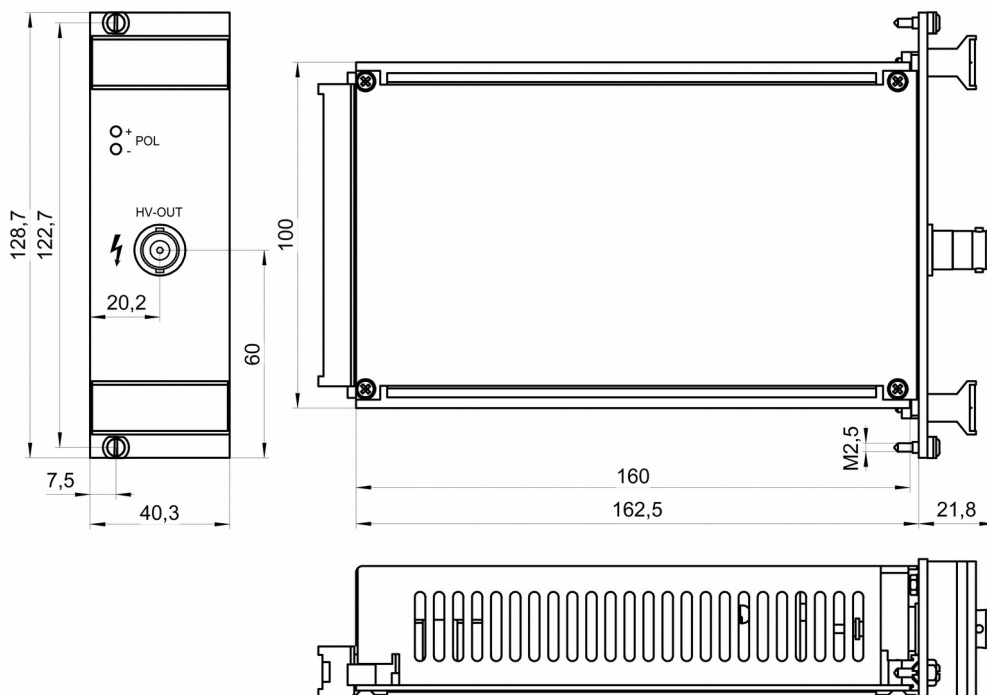

Figure 2: dimensional drawing CPS <7kV 3UC

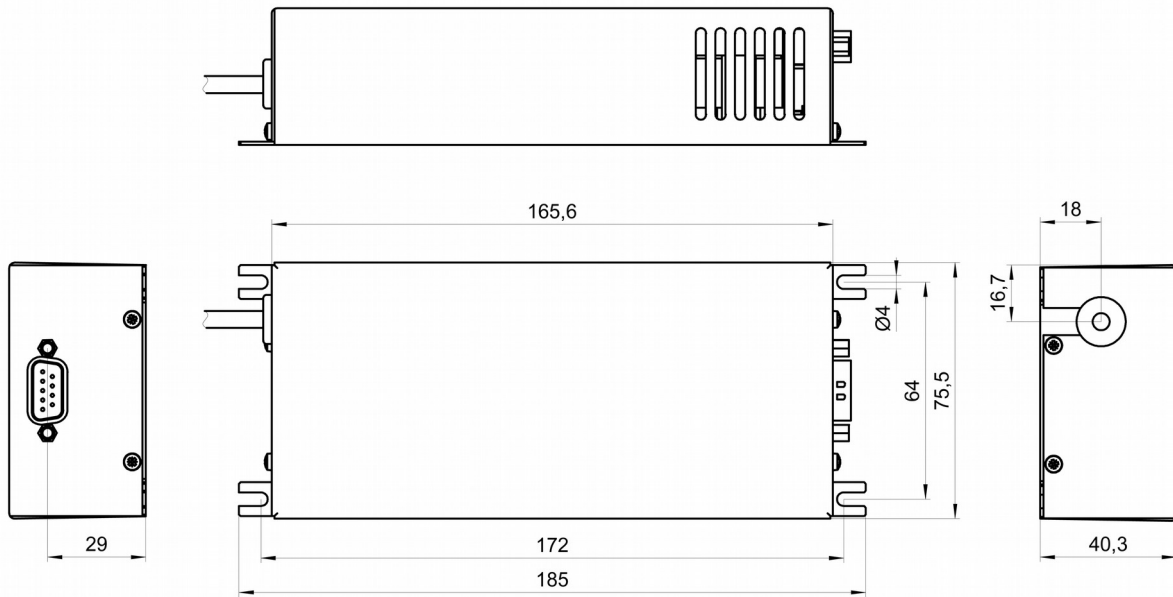

Figure 3: dimensional drawing CPS 10kV - 20kV

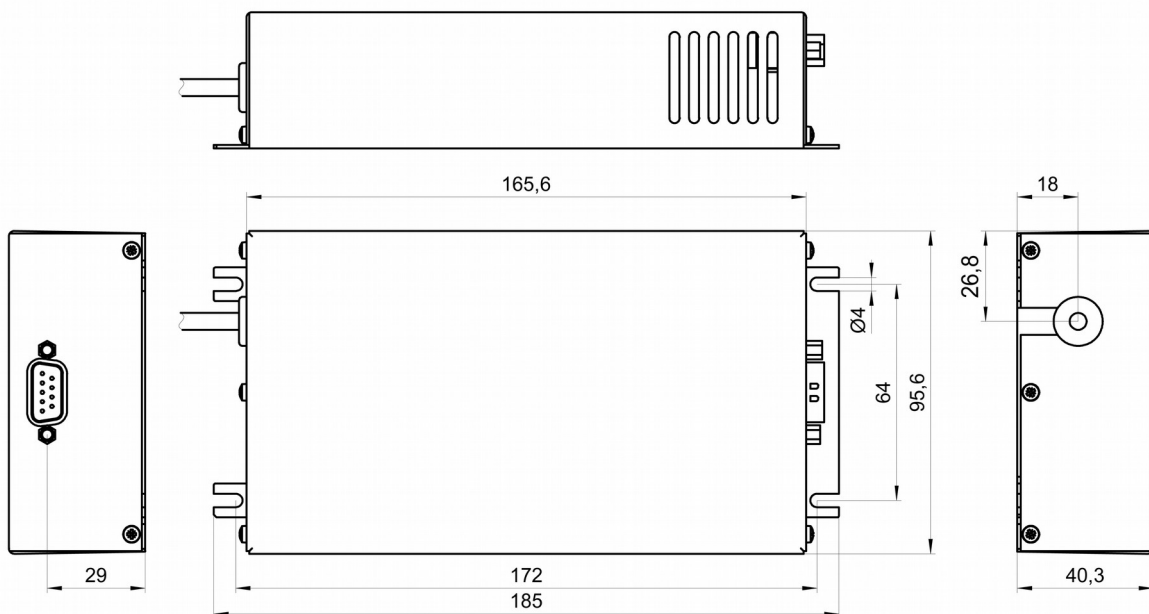

Figure 4: dimensional drawing CPS 30kV

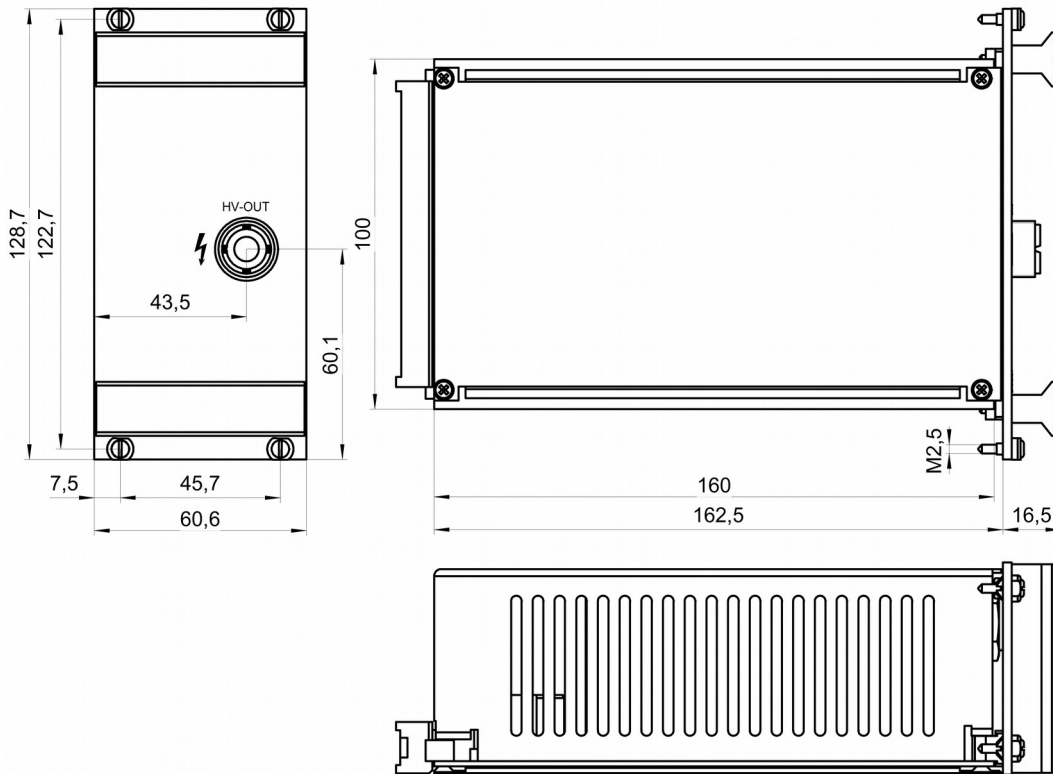

Figure 5: dimensional drawing CPS >20kV 3UC

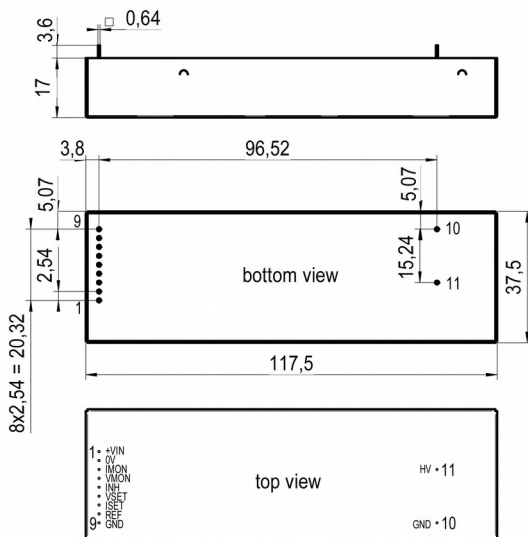



Figure 6: dimensional drawing CPSmini

4 Connectors and PIN assignments

4.1 HV connectors

HV CONNECTORS			
Name	S08 / SHV	G11 / G21 / G31	
Figure			

CONNECTORS PART NUMBERS (manufacturer code / iseq accessory parts item code)			
POWER SUPPLY SIDE		CABLE SIDE	
SHV (ROSENBERGER)			
Socket	57S501-200N3	Connector	57K101-006N3 / Z590162
S08 (RADIALL) - 8 kV			
Socket	R317.580.000	Connector	R317.005.000 / Z592474
G11 (GES) - 10 kV			
Socket	7311020	Connector	7310020 / Z592516
G21 (GES) - 20 kV			
Socket	7321020	Connector	7320020 / Z592391
G31 (GES) - 30 kV			
Socket	7331053	Connector	7331052 / Z592501

4.2 Interface connector D-SUB 9 (CPS metal box)

PIN	NAME	DESCRIPTION	VALUE
1	OV ¹⁾	Supply ground	0 V
2	IMON	I_{mon} Monitor voltage of output current	0 .. 5 V (opt. 0 .. 10 V)
3	INH	Inhibit, LOW = active, shut down the output voltage	TTL-level, LOW → HV OFF HIGH or n.c. → HV ON
4	ISET	I_{set} Set voltage of output current	0 .. 5 V (opt. 0 .. 10 V)
5	VIN	V_{in} Supply voltage	+24 V DC
6	GND ¹⁾	Signal ground	
7	VMON	V_{mon} Monitor voltage	0 .. 5 V (opt. 0 .. 10 V)
8	VSET	V_{set} Set value of output voltage	0 .. 5 V (opt. 0 .. 10V)
9	REF	V_{ref} Internal reference voltage	5 V (opt. 10V)

Notes:
Case is connected to GND
¹⁾ internally connected

Table 4: PIN Assignment D-SUB 9

4.3 System connector H15 (CPS 3UC)

PIN	NAME	DESCRIPTION	VALUE
8	REF	V _{ref} Internal reference voltage	5 V (opt. 10 V)
10	0V ¹	Supply ground	
12	GND ¹	Signal ground	
14	IMON	I _{mon} Monitor voltage of output current	0 .. 5 V (opt. 0 .. 10 V)
16	ON	HV ON/OFF with voltage ramp	TTL-level, LOW → HV ON HIGH or n.c. → HV OFF
20	VSET	V _{set} Set value of output voltage	0 .. 5 V (opt. 0 .. 10 V)
24	VMON	V _{mon} Monitor voltage	0 .. 5 V (opt. 0 .. 10 V)
26	VIN	V _{in} Supply voltage	+24 V DC
28	ISET	I _{set} Set voltage of output current	0 .. 5 V (opt. 0 .. 10 V)
30	KILL_ENA ²	Killenable, high active	TTL-level
32	INH	Inhibit, LOW = active, shut down the output voltage	TTL-level, LOW → HV OFF HIGH or n.c. → HV ON

Notes:
Case is connected to GND
¹) internally connected
²) If KillEnable is active the occur of Inhibit will trigger a Kill-signal. This signal will switch off the HV immediately without ramp.

Table 5: PIN Assignment 3U H15

4.4 Interface connector PIN (CPS mini)

PIN	NAME	DESCRIPTION	VALUE
1	VIN	V _{in} Supply voltage	+24 V DC
2	0V ²	Supply ground	
3	IMON	I _{mon} Monitor voltage of output current	0 .. 5 V
4	VMON	V _{mon} Monitor voltage	0 .. 5 V
5	INH	Inhibit, LOW = active, shut down the output voltage	TTL-level, LOW → V _{out} = 0V HIGH or n.c. → HV ON
6	VSET	V _{set} Set value of output voltage	0 .. 5 V
7	ISET	I _{set} Set voltage of output current	0 .. 5 V
8	REF	V _{ref} Internal reference voltage	5 V
9	GND ¹	Signal ground	
10	GND ¹	HV ground	
11	HV	V _{out} High voltage output	

Notes:
Case is connected to GND
¹) internally connected
²) electrically isolated from GND

Tabelle 6: PIN Assignment CPS mini

5 Order guides

CONFIGURATION ORDER GUIDE (item code parts)								
CP	030	405	P	24	50	000	02	00
Type CPS	V _{nom}	I _{nom} (nA)	Polarity	Input Voltage	Monitor Voltage	Option (hex)	HV-Connector	Customized Version
CP = Metal box CK = 3U Casette CM = CPS mini	three significant digits • 100V For Examble: 030 = 3000V	two significant digits + number of zeros For Examble: 405 = 4mA	p = positive n = negative	two significant digits For Examble: 24 = 24 Volt	two significant digits 1.th hex • 1V 2.th dez • 0,1V For Examble: A0 = 10V	three significant characters	00 = Cable 02 = SHV 03 = S08 06 = G11 07 = G21 08 = G31 (see Connectors and PIN assignments)	00 = non

Table 7: Configuration item code

CABLE ORDER GUIDE				
POWER SUPPLY SIDE CONNECTOR	CABLE CODE	CABLE DESCRIPTION	LOAD SIDE CONNECTOR	ORDER CODE LLL = length in m ⁽¹⁾
SHV	04	HV cable shielded 30kV (HTV-30S-22-2)	open	SHV_C04-LLL
S08	04	HV cable shielded 30kV (HTV-30S-22-2)	open	S08_C04-LLL
G11	02	Lemo HV cable shielded 30kV (Lemo 130660)	open	G11_C02-LLL
G21	02	Lemo HV cable shielded 30kV (Lemo 130660)	open	G21_C02-LLL
G31	02	Lemo HV cable shielded 30kV (Lemo 130660)	open	G31_C02-LLL

¹⁾ Length building examples: 10cm → 0.1, 2.5m → 2.5, 12m → 012, 999m → 999

Table 8: Item code parts for different configurations

6 Warranty & Service

This device is made with high care and quality assurance methods. The standard factory warranty is 12 months. Please contact the iseg sales department if you wish to extend the warranty.

ATTENTION



Repair and maintenance may only be performed by trained and authorized personnel.

For repair please follow the RMA instructions on our website: www.iseg-hv.com/en/support/rma

7 Disposal

INFORMATION



All high-voltage equipment and integrated components are largely made of recyclable materials. Do not dispose the device with regular residual waste. Please use the recycling and disposal facilities for electrical and electronic equipment available in your country.

8 Manufacturer's contact

iseg Spezialelektronik GmbH

Bautzner Landstr. 23

01454 Radeberg / OT Rossendorf

GERMANY

FON: +49 351 26996-0 | FAX: +49 351 26996-21

www.iseg-hv.com | info@iseg-hv.de | sales@iseg-hv.de