

Technical documentation

Last changed on: 2022-08-10

CPS series

Built-in or System Capable Compact High Voltage Module

- Versions from 500 V – 30 kV
- patented resonance converter technology
- available as metal-box or 3U MMC version
- combinable in a multichannel THQ AC/DC HV power supply
- INHIBIT
- low ripple and noise, low EMI
- hardware limits for voltage and current



Document history

Version	Date	Major changes
3.3	2022-08-10	Improved documentation, Description the signals on H15 connector
3.2	2021-12-15	Improved documentation (technical data 3UC), Revision "A"
3.1	2021-08-09	Improved documentation, separation from 3UC and box modules in 2 tables, new dimensions figures, item Code with revision and customization, Table of content, glossary, HV-connector adds in configurations, chapters overview, fix it dimensions for 20kV module, separation of the modules CPSmini, improved overview for the connections
3.0	2020-08-18	Improved documentation (safety information, Set / Monitor accuracy)
2.5	2020-07-09	Improved documentation, Intended Use
2.4	2020-01-13	Error correction
2.3	2019-09-06	improved description
2.2	2019-06-27	Error correction
2.1	2019-06-11	Error correction Improved description
2.0	2018-06-13	Improved documentation
	2017-09-21	Relayouted documentation

Disclaimer / Copyright

Copyright © 2022 by iseg Spezialelektronik GmbH / Germany. All Rights Reserved.

This document is under copyright of iseg Spezialelektronik GmbH, Germany. It is forbidden to copy, extract parts, duplicate for any kind of publication without a written permission of iseg Spezialelektronik GmbH. This information has been prepared for assisting operation and maintenance personnel to enable efficient use.

The information in this manual is subject to change without notice. We take no responsibility for any mistake in the document. We reserve the right to make changes in the product design without reservation and without notification to the users. We decline all responsibility for damages and injuries caused by an improper use of the device.

Safety

This section contains important security information for the installation and operation of the device. Failure to follow safety instructions and warnings can result in serious injury or death and property damage.

Safety and operating instructions must be read carefully before starting any operation.

We decline all responsibility for damages and injuries caused which may arise from improper use of our equipment.

Depiction of the safety instructions

DANGER!



DANGER!

“Danger!” indicates a severe injury hazard. The non-observance of safety instructions marked as “Danger!” will lead to possible injury or death.

WARNING!



WARNING!

“Warning!” indicates an injury hazard. The non-observance of safety instructions marked as “Warning!” could lead to possible injury or death.

CAUTION!



CAUTION!

Advices marked as “Caution!” describe actions to avoid possible damages to property.

INFORMATION



INFORMATION

Advices marked as “Information” give important information.



Read the manual.



Attention high voltage!



Important information.

Intended Use

The device may only be operated within the limits specified in the data sheet. The permissible ambient conditions (temperature, humidity) must be observed. The device is designed exclusively for the generation of high voltage as specified in the data sheet. Any other use not specified by the manufacturer is not intended. The manufacturer is not liable for any damage resulting from improper use.

Qualification of personnel

A qualified person is someone who is able to assess the work assigned to him, recognize possible dangers and take suitable safety measures on the basis of his technical training, his knowledge and experience as well as his knowledge of the relevant regulations.

General safety instructions

- Observe the valid regulations for accident prevention and environmental protection.
- Observe the safety regulations of the country in which the product is used.
- Observe the technical data and environmental conditions specified in the product documentation.
- You may only put the product into operation after it has been established that the high-voltage device complies with the country-specific regulations, safety regulations and standards of the application.
- The high-voltage power supply unit may only be installed by qualified personnel.

Important safety instructions

WARNING!



WARNING!

To avoid injury of users it is not allowed to open the unit. There are no parts which can be maintained by users inside of the unit. Opening the unit will void the warranty.

WARNING!



WARNING!

The high-voltage cable must be professionally connected to the consumer/ load and the connection insulated with the appropriate dielectric strength. Do not power the consumer/ load outside of its specified range.

WARNING!



WARNING!

Before connecting or disconnecting HV cables or any operation on the HV output or the application, the unit has to be switched off and discharge of residual voltage has to be finished. Depending on application residual voltages can be present for long time periods.

WARNING!



WARNING!

Do not operate the unit in wet or damp conditions.

WARNING!



WARNING!

Do not operate the unit in an explosive atmosphere.

WARNING!



WARNING!

Do not operate the unit if you suspect the unit or the connected equipment to be damaged.

CAUTION!



CAUTION!

The devices (3UC) must only be used in combination with iseg approved crates.

INFORMATION



INFORMATION

Please check the compatibility with the devices used.

Table of Contents

Document history	2
Disclaimer / Copyright	2
Safety	3
Depiction of the safety instructions	3
Intended Use	4
Qualification of personnel	4
General safety instructions	4
Important safety instructions	5
1. General description	7
2. Overview	7
2.1. CPS – compact metal box	7
2.2. CPS – 3UC Euro cassette	8
3. Technical Data	9
3.1. Specifications	9
3.2. Configurations	10
3.3. Options	11
3.4. Functional description	11
3.5. separation supply ground from signal ground	12
4. Dimensional drawings	13
4.1. compact metal box	13
4.2. 3UC Euro cassette	14
5. Connectors and PIN assignments	16
5.1. Interface connector D-SUB 9 (compact metal box)	17
5.2. System connector H15 (3UC Euro cassette)	18
6. Order guides	19
7. Revisions	19
8. Appendix	20
9. Glossary	21
10. Warranty & Service	22
11. Disposal	22
12. Manufacturer contact	22

1. General description

CPS modules are highly stable analog controlled High Voltage Power supplies. They are available as compact metal box or system capable in 3U Eurocassette standard. Modules of the CPS series can be used as standalone DC/DC converters and also be combined to a multichannel AC/DC supply in a THQ series or integrated in a modular MMC system. The output voltage is controllable with an analog interface with either a potentiometer (internal reference voltage) or an input analog control voltage. To protect the connected load the modules are equipped with INHIBIT, current and voltage limits.

Customized versions can be produced on request.

2. Overview

2.1. CPS – compact metal box

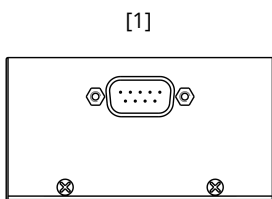

Figure 1: Front side with remote



Figure 2: side view

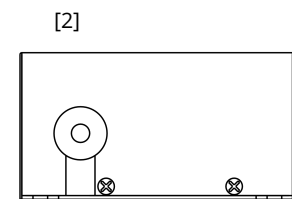

Figure 3: Back side - cable

Number	Description	Description	Detailed explanation in chapter
[1]	Interface connector	Power supply and control signal	3.4 Functional description, 5.1 Interface connector D-SUB 9 (compact metal box)
[2]	HV cable	HV output	Table 2: Configurations: CPS – compact metal box

2.2. CPS – 3UC Euro cassette

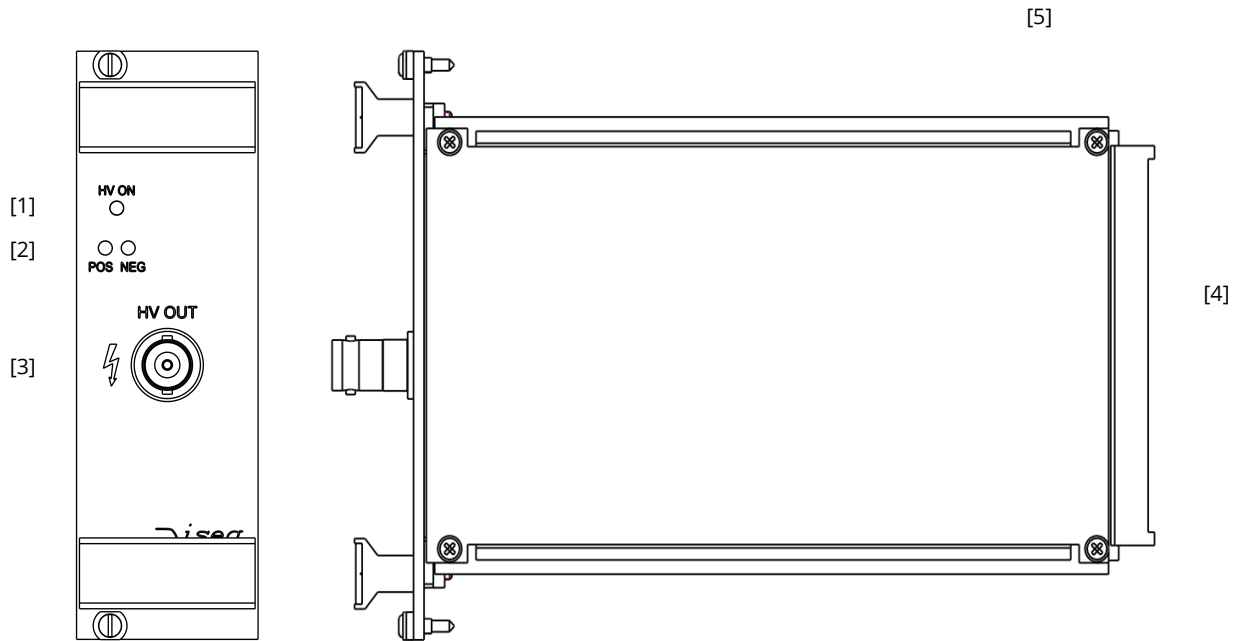

Figure 4: Front view

Figure 5: Back side Sample

Number	Description	Detailed explanation in chapter	
[1] ⁽¹⁾	HV ON LED	Signals output voltage	Signals the output voltage over 64V
[2]	Polarity LED	the module has negative or positive voltage output (factory fixed)	3 Technical Data
[3]	HV connector		5 Connectors and PIN assignments, Table 3: Configurations: CPS – 3U Euro cassette
[4]	System connector	Power supply and control signal	3.4 Functional description, 5 Connectors and PIN assignments, 5.2 System connector H15 (3UC Euro cassette)
[5] ⁽¹⁾	Jumper	separation supply ground from signal ground	3.5 separation supply ground from signal ground
Notes: ¹⁾ – only module up revision “A”			

3. Technical Data

3.1. Specifications

SPECIFICATIONS	CPS- compact metal box	CPS - 3UC Euro cassette
Out voltage V_{nom}	500 V – 30 kV	
Polarity	Factory fixed, positive or negative	
Ripple and noise ($f > 10$ Hz) ¹⁾	< 10 kV: typ. $< 2 \cdot 10^{-5} \cdot V_{nom}$ ≥ 10 kV: typ. $< 5 \cdot 10^{-5} \cdot V_{nom}$	
Stability – $[\Delta V_{out}$ vs. $\Delta V_{in}]$ ¹⁾	$< 1 \cdot 10^{-4} \cdot V_{nom}$	
Stability – $[\Delta V_{out}$ vs. $\Delta R_{load}]$ ¹⁾	$< 2 \cdot 10^{-4} \cdot V_{nom}$	
Temperatur coefficient	100 ppm / K	
Supply voltage V_{in}	22.8 – 25.2V	
Supply current I_{in} at $V_{out} = 0$ at $V_{out} = V_{nom}$ / with load	< 50 mA < 800 mA	
Set / Monitor voltage	0 – 5 V opt. 0 – 10 V	0 – 5 V
Set / Monitor accuracy	$\pm 1 \% \cdot V_{nom}$	
Voltage ramp up/down	$0.25 \cdot V_{nom} / s$	
Protection	Overload and short circuit protected, INHIBIT, V/I-limit (ATTENTION: there is only one short circuit or arc per second allowed!)	
System / Remote connector	D-Sub 9	H15
HV connector	HV-cable	See Table 3: Configurations: CPS – 3U Euro cassette
Case	metal box moulded	3U cassette (MMC capable)
Dimensions – L/W/H	500V – 7kV → 155/75/40 mm ³ 10kV – 20kV → 185/75/40 mm ³ 30kV → 185/95/40mm ³	500V – 7kV → 8HP / 40.64 mm ³ 10kV – 30kV → 12HP / 61.0 mm ³
Operating temperature	0 – 50 °C	
Storage temperature	-20 – 60 °C	
Humidity	max. 70 %	
Notes:	¹⁾ Specifications for stability, ripple and noise are guaranteed in the range $2\% \cdot V_{nom} < V_{out} \leq V_{nom}$, $I_{set} \geq 4\% I_{nom}$	

Table 1: Technical data: Specifications

3.2. Configurations

CONFIGURATIONS CPS – compact metal box								
	V _{nom}	I _{nom}	Standard Ripple (mV _{p-p})	Internal Capacitance nominal (nF)	Damping Resistor (kOhm)	Discharge Resistor (MOhm)	HV connector	Item Code
CPx 05 206 24 y	500 V	20 mA	10	620	0.05	55	cable	CP005206x24oooooccrk
CPx 10 106 24 y	1 kV	10 mA	20	250	0.1	55	cable	CP010106x24oooooccrk
CPx 15 805 24 y	1.5 kV	8 mA	30	120	0.1	55	cable	CP015805x24oooooccrk
CPx 20 605 24 y	2 kV	6 mA	40	65	0.1	55	cable	CP020605x24oooooccrk
CPx 30 405 24 y	3 kV	4 mA	60	42	0.1	55	cable	CP030405x24oooooccrk
CPx 40 305 24 y	4 kV	3 mA	80	30	0.2	500	cable	CP040305x24oooooccrk
CPx 50 205 24 y	5 kV	2 mA	100	30	0.7	500	cable	CP050205x24oooooccrk
CPx 70 155 24 y	7 kV	1.5 mA	150	5	0.7	500	cable	CP070155x24oooooccrk
CPx 100 105 24 y	10 kV	1 mA	500	14	13	660	cable	CP100105x24oooooccrk
CPx 150 604 24 y	15 kV	0.6 mA	750	3.5	13	660	cable	CP150604x24oooooccrk
CPx 200 504 24 y	20 kV	0.5 mA	1000	3	13	660	cable	CP200504x24oooooccrk
CPx 300 304 24 y	30 kV	0.3 mA	1500	1.7	20	660	cable	CP300304x24oooooccrk

Notes:
replacement characters: o – options, c – connector, r – revision, k – customization, x – polarity (negative/positive), y – monitor voltages

Table 2: Configurations: CPS – compact metal box

CONFIGURATIONS CPS – 3UC Euro cassette								
	V _{nom}	I _{nom}	Standard Ripple (mV _{p-p})	Internal Capacitance nominal (nF)	Damping Resistor (kOhm)	Discharge Resistor (MOhm)	HV connector (standard)	Item Code
CPx 05 206 24 5	500 V	20 mA	10	620	0.05	55	SHV	CK005206x2450oooooccrk
CPx 10 106 24 5	1 kV	10 mA	20	250	0.1	55	SHV	CK010106x2450oooooccrk
CPx 15 805 24 5	1.5 kV	8 mA	30	120	0.1	55	SHV	CK015805x2450oooooccrk
CPx 20 605 24 5	2 kV	6 mA	40	65	0.1	55	SHV	CK020605x2450oooooccrk
CPx 30 405 24 5	3 kV	4 mA	60	42	0.1	55	SHV	CK030405x2450oooooccrk
CPx 40 305 24 5	4 kV	3 mA	80	30	0.2	500	SHV	CK040305x2450oooooccrk
CPx 50 205 24 5	5 kV	2 mA	100	30	0.7	500	SHV	CK050205x2450oooooccrk
CPx 70 155 24 5	7 kV	1.5 mA	150	5	0.7	500	S08	CK070155x2450oooooccrk
CPx 100 105 24 5	10 kV	1 mA	500	14	13	660	G11	CK100105x2450oooooccrk
CPx 150 604 24 5	15 kV	0.6 mA	750	3.5	13	660	G21	CK150604x2450oooooccrk
CPx 200 504 24 5	20 kV	0.5 mA	1000	3	13	660	G21	CK200504x2450oooooccrk
CPx 300 304 24 5	30 kV	0.3 mA	1500	1.7	20	660	G31	CK300304x2450oooooccrk

Notes:
replacement characters: o – options, c – connector, r – revision, k – customization, x – polarity (negative/positive)

Table 3: Configurations: CPS – 3U Euro cassette

3.3. Options

ORDER INFO	INFO	EXAMPLE
POLARITY	Positive: x = p Negative: x = n	CPp 05 206
Set / monitor voltage ⁽¹⁾	0 – 5 V, standard y=5 0 – 10 V, optional y=10	
3UC	3U, Height unit based on the 19-inch standard housing, MMC capable version	
Notes: ¹⁾ – only for compact metal box		

Table 4: Technical data: Options and order information

3.4. Functional description

If the high voltage excitation is switched on and off via PIN ON (3UC module), it rises or falls by means of ramp up to the maximum set voltage via V_{SET} .

Via PIN INH (Box modules) the voltage generation is switched on with ramp, but switched off without ramp. A monitor voltage for the output current and output voltage is available via the I_{MON} and V_{MON} connections.

The pin REF (reference) can be used for the V_{SET} voltage via an additional circuit (see Figure 6: VSET).

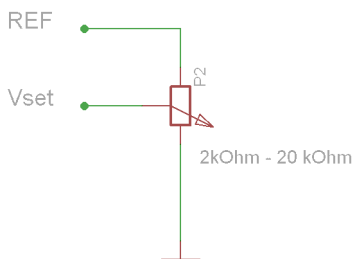

Figure 6: VSET

3.5. separation supply ground from signal ground

INFORMATION



Only available from revision "A".

INFORMATION

In version 3UC, the supply ground (0V) can be separated from the signal ground (GND) by removing the jumper J1. See Figure 7: view of the top; and Figure 8: detail view of figure 7.

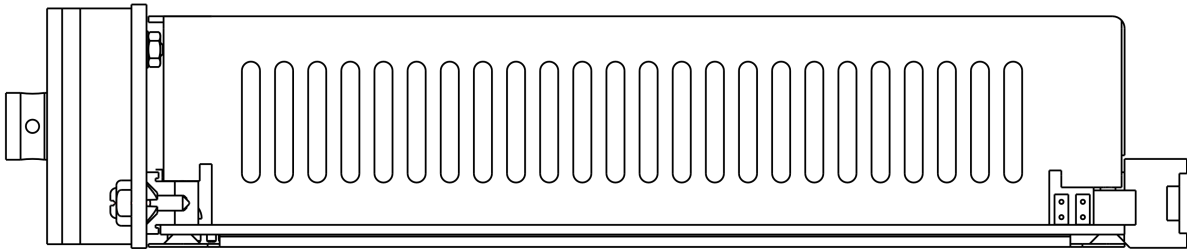

Figure 7: view of the top

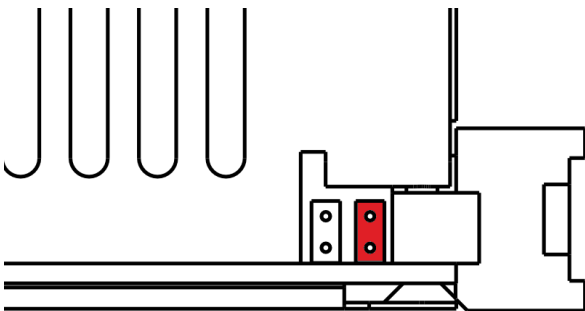

Figure 8: detail view of figure 7

Jumper	reserved	J1
	left	right, red marked

4. Dimensional drawings

4.1. compact metal box

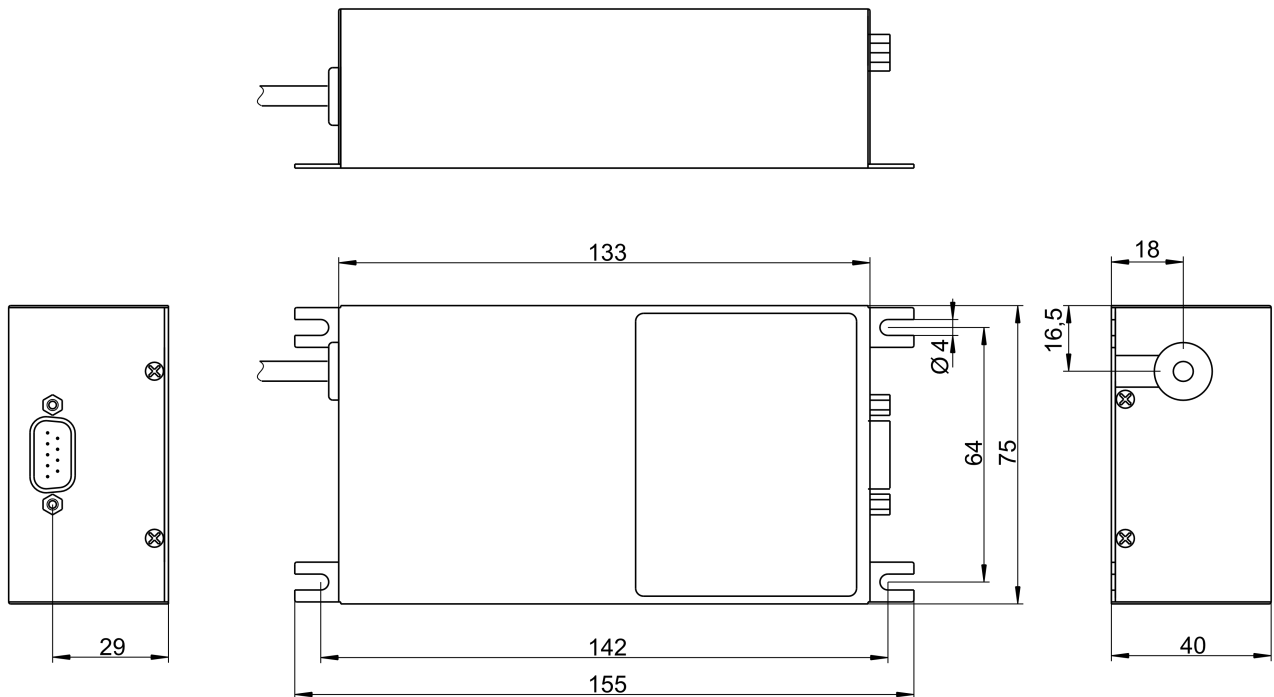

Figure 9: CPS compact metal box up to 7kV

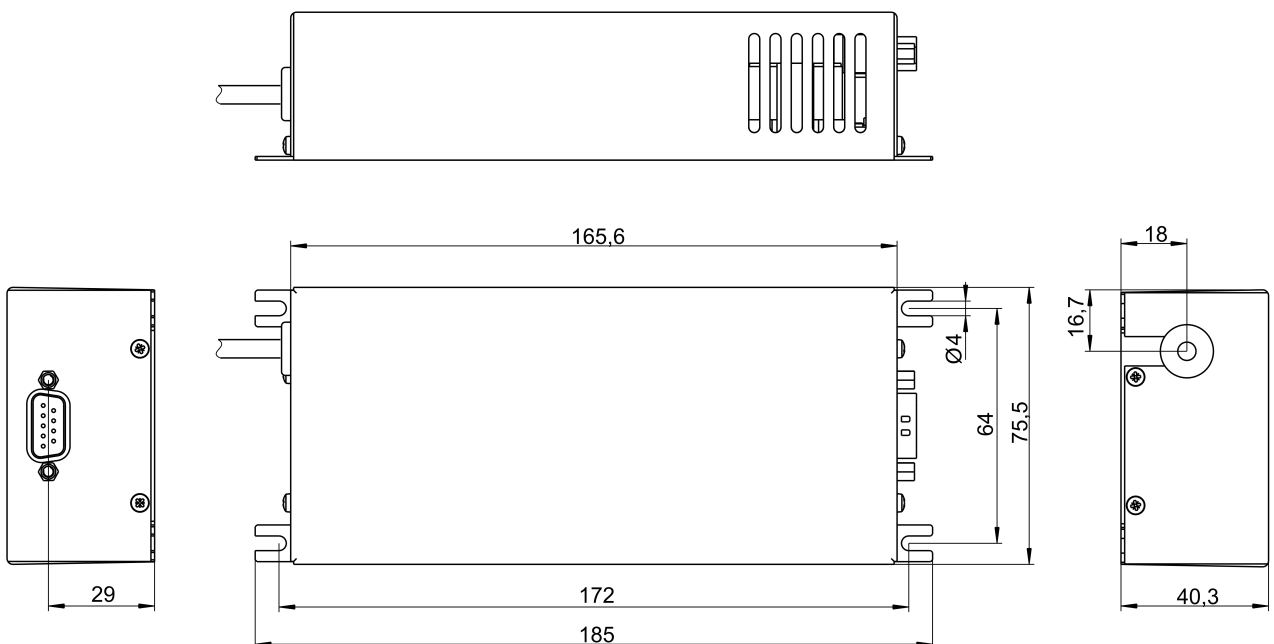

Figure 10: CPS compact metal box 10kV - 20kV

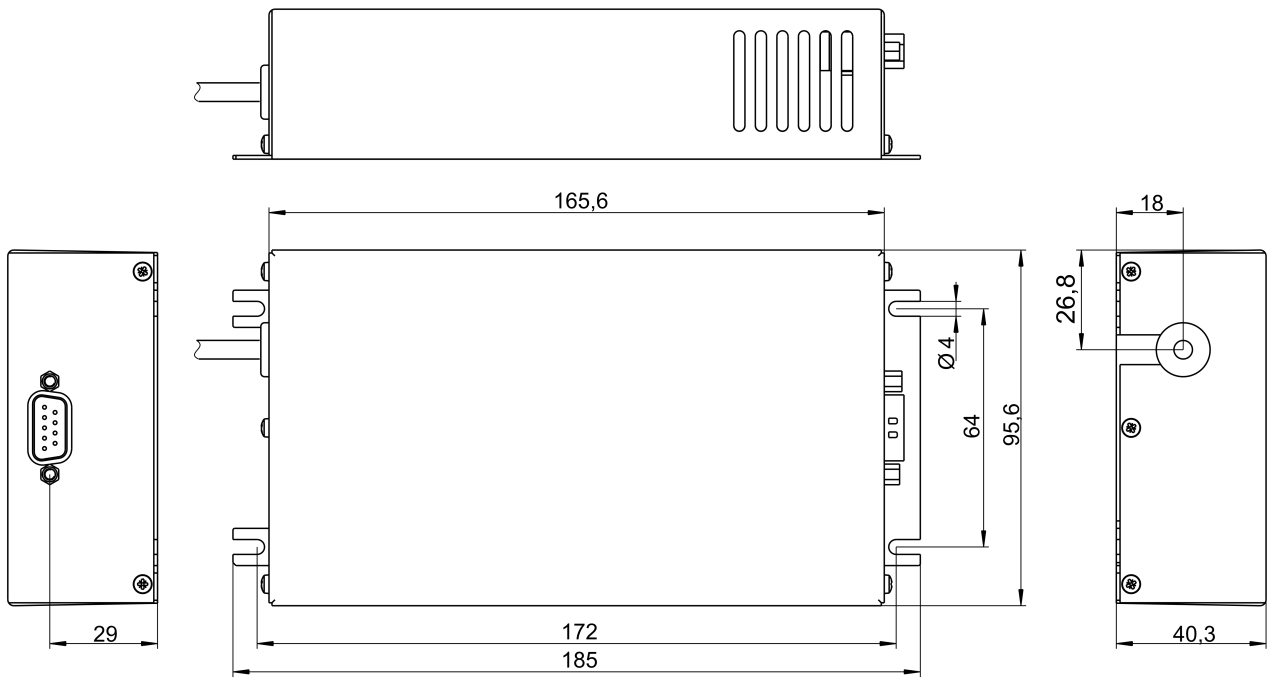

Figure 11: CPS compact metal box 30kV

4.2. 3UC Euro cassette

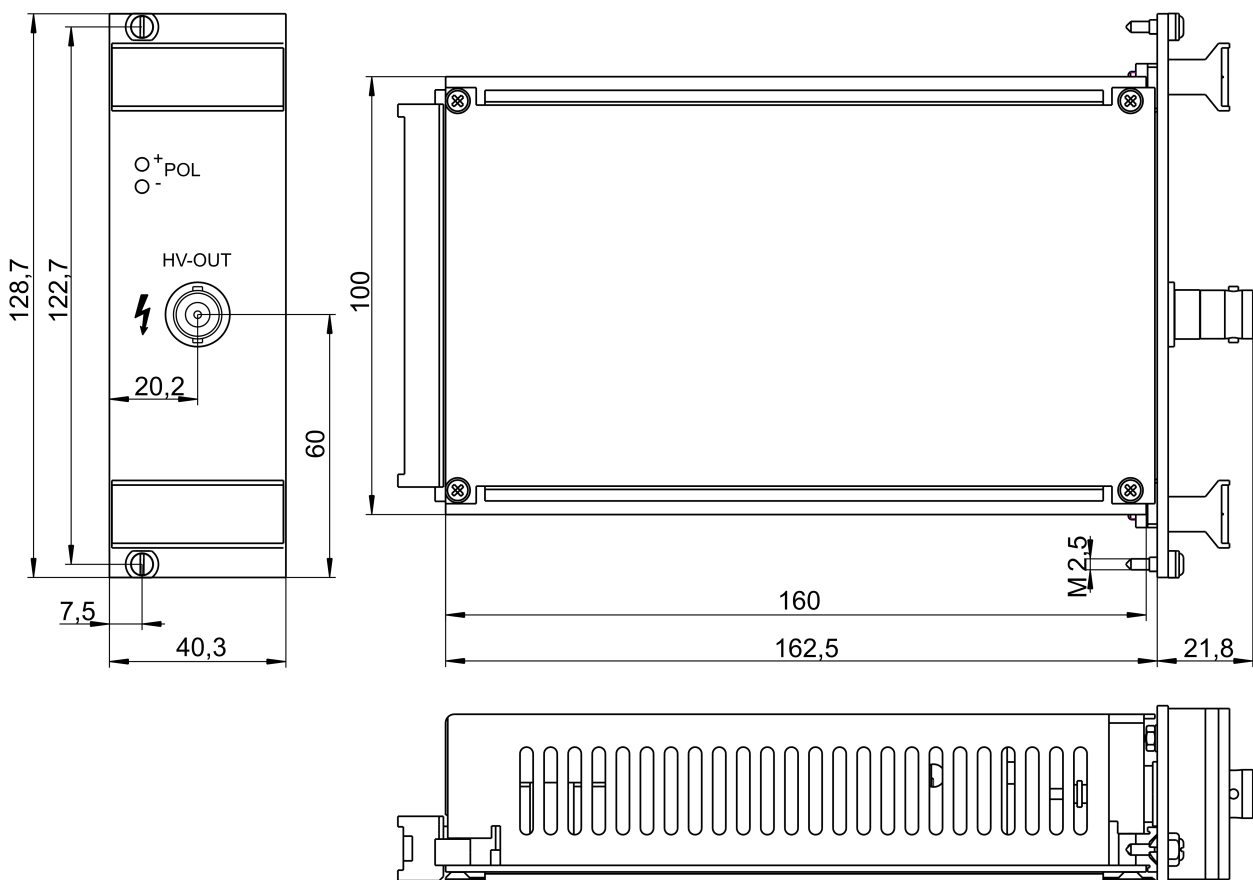

Figure 12: CPS - 3UC Euro cassette up to 7kV, 8HP

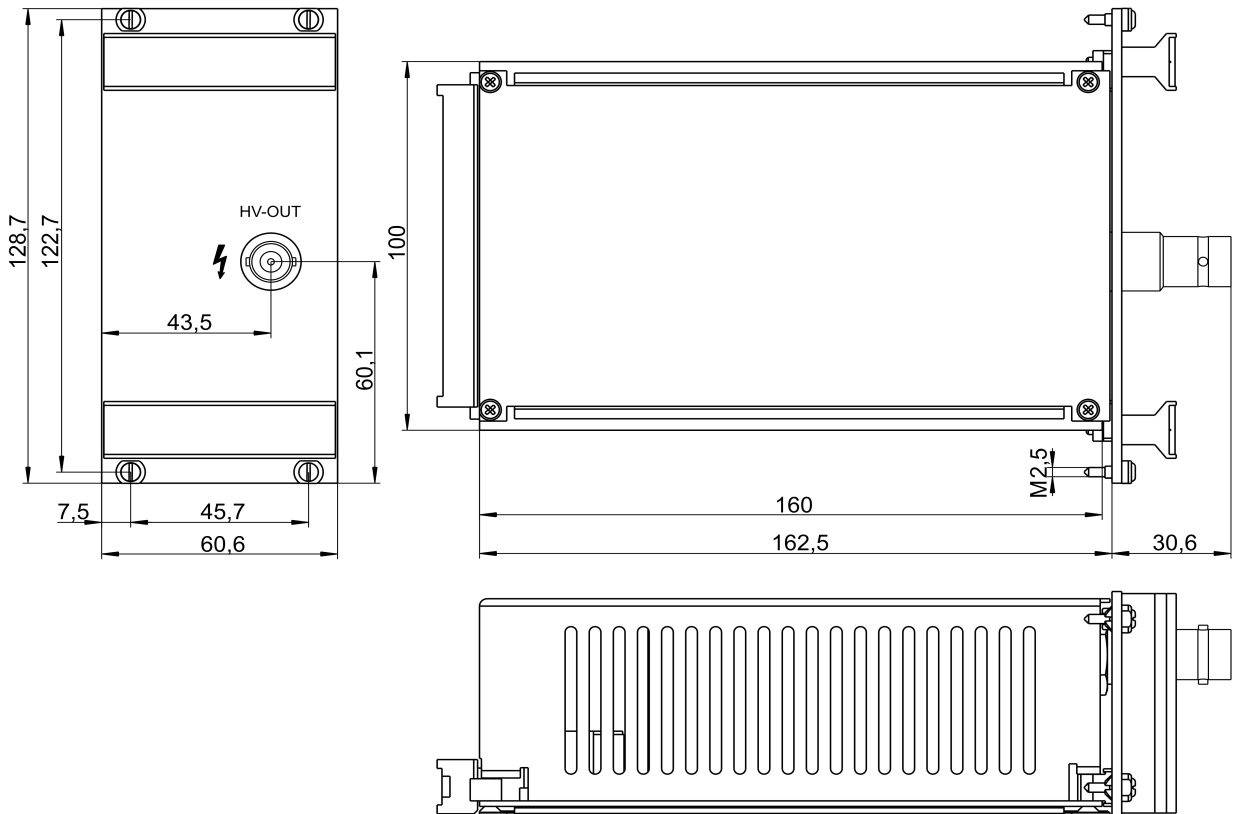

Figure 13: CPS - 3UC Euro cassette for 10 - 20kV, 12HP

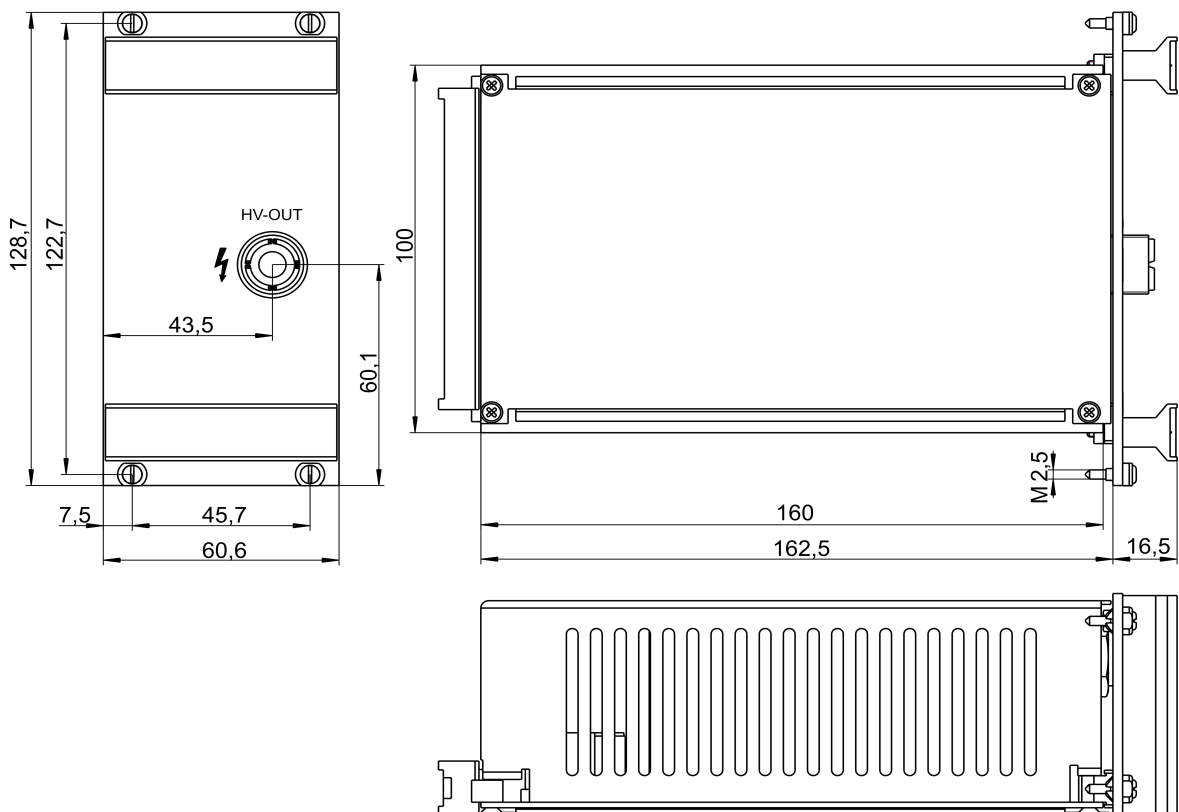

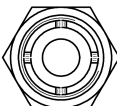
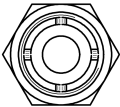
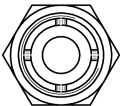
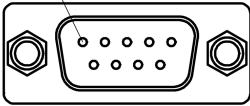

Figure 14: CPS - 3UC Euro cassette for 30kV, 12HP

5. Connectors and PIN assignments

CONNECTORS – POWER SIDE		PART NUMBERS (manufacturer code / iseg accessory parts item code)	
SHV		CABLE SIDE	
 Figure 15	part number	57K101-006N3	
	manufacturer	Rosenberger	
	iseg part number	Z590162	
S08		CABLE SIDE	
 Figure 16	part number	R317.005.000	
	manufacturer	Radiall	
	iseg part number	Z592474	
G11		CABLE SIDE	
 Figure 17	part number	7310020	
	manufacturer	GES electronic	
	iseg part number	Z592516	
G21		CABLE SIDE	
 Figure 18	part number	7320020	
	manufacturer	GES electronic	
	iseg part number	Z592391	
G31		CABLE SIDE	
 Figure 19	part number	7331052	
	manufacturer	GES electronic	
	iseg part number	Z592501	
D-SUB9 - male		CABLE SIDE	
PIN 1  Figure 20	connector	D SUD9	
	manufacturer	various manufacturer	
	iseg part number		

CONNECTORS		PART NUMBERS (manufacturer code / iseg accessory parts item code)	
H15		CABLE SIDE	
 Figure 21		connector	Female power plug type H15, compatible with iseg crates
		manufacturer	various manufacturer
		iseg part number	

Table 5

5.1. Interface connector D-SUB 9 (compact metal box)

PIN	NAME	DESCRIPTION	VALUE
1	0V ¹⁾	Supply ground	0 V
2	IMON	I_{mon} Monitor voltage of output current	0 ... 5 V (optionally: 0 ... 10 V)
3	INH	Inhibit, LOW = active, shut down the output voltage	TTL-level: LOW → HV OFF HIGH or n.c. → HV ON
4	ISET	I_{set} Set voltage of output current	0 ... 5 V (optionally: 0 ... 10 V)
5	VIN	V_{in} Supply voltage	+24 V DC
6	GND ¹⁾	Signal ground	
7	VMON	V_{mon} Monitor voltage	0 ... 5 V (optionally: 0 ... 10 V)
8	VSET	V_{set} Set value of output voltage	0 ... 5 V (optionally: 0 ... 10 V)
9	REF	V_{ref} Internal reference voltage	5 V (optionally: 10V)

Notes:
Case is connected to GND
¹⁾ internally connected

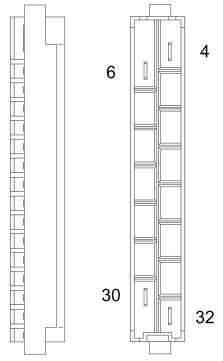
Table 6: PIN Assignment D-SUB 9

5.2. System connector H15 (3UC Euro cassette)

PIN	NAME	DESCRIPTION	VALUE
6	0V	Supply ground	
8	REF	V_{ref} Internal reference voltage	5 V
10	0V	Supply ground	
12	GND	Signal ground	
14	IMON	I_{mon} Monitor voltage of output current	0 ... 5 V
16	ON	HV ON/OFF with voltage ramp	TTL-level: LOW → HV ON HIGH or not connected → HV OFF
18	VIN_C ⁽¹⁾	$V_{in,s}$ Supply voltage (Control)	+24 V DC
20	VSET	V_{set} Set value of output voltage	0 ... 5 V
24	VMON	V_{mon} Monitor voltage	0 ... 5 V
26	VIN ⁽¹⁾	V_{in} Supply voltage (Power)	+24 V DC
28	ISET	I_{set} Set voltage of output current	0 ... 5 V
30	KILL_ENA ⁽²⁾	Killenable, high active	TTL-level
32	INH	Inhibit, LOW = active, shut down the output voltage	TTL-level: LOW → HV OFF HIGH or not connected → HV ON

Notes:

Case is connected to **0V** and with Jumper J1 connected to **GND**, see chapter 3.5 separation supply ground from signal ground

⁽¹⁾ internally connected

⁽²⁾ If KillEnable is active the occur of Inhibit will trigger a Kill-signal. This signal will switch off the HV immediately without ramp.

Table 7: PIN Assignment 3U H15

6. Order guides

CONFIGURATION ORDER GUIDE (item code parts)									
Cx	030	405	x	24	50	000	02	0	0
Type	V _{nom}	I _{nom} (nA)	Polarity	Input Voltage	Monitor Voltage	Option	HV-Connector	Revision	Customized Version
x = P Metal box x = K 3U Cassette x = T for THQ	three significant digits • 100V For Example: 030 = 3000V	two significant digits + number of zeros For Example: 405 = 4mA	P = positive N = negative	two significant digits For Example: 24 = 24 Volt	two significant digits 1.th hex • 1V 2.th dez • 0,1V For Example: A0 = 10V	three significant characters	00 = Cable 02 = SHV 03 = S08 06 = G11 07 = G21 08 = G31 see 5 Connectors and PIN assignments	one digit 0 = no revision For Example: A = first revision B = second revision	one digit 0 = no custo- mization

Table 8: Configuration item code

CABLE ORDER GUIDE					
POWER SUPPLY SIDE CONNECTOR	V _{max}	CABLE CODE	CABLE DESCRIPTION	LOAD SIDE CONNECTOR	ORDER CODE LLL = length in m ⁽¹⁾
SHV	≤ 5 kV	04	HV cable shielded 30kV (HTV-30S-22-2)	open	SHV_C04-LLL
S08	≤ 8 kV	04	HV cable shielded 30kV (HTV-30S-22-2)	open	S08_C04-LLL
G11	≤ 10 kV	02	Lemo HV cable shielded 30kV (Lemo 130660)	open	G11_C02-LLL
G21	≤ 20 kV	02	Lemo HV cable shielded 30kV (Lemo 130660)	open	G21_C02-LLL
G31	≤ 30 kV	02	Lemo HV cable shielded 30kV (Lemo 130660)	open	G31_C02-LLL

Notes:
¹⁾Length building examples: 10cm → 0.1, 2.5m → 2.5, 12m → 012, 999m → 999

Table 9: Guideline for cable ordering

7. Revisions

date	revision	modification
2021-12-16	A	separation supply ground from signal ground

Table 10

8. Appendix

For more information please use the following download links:

This document
https://iseq-hv.com/download/DC_DC/CPS/iseq_datasheet_CPS_en.pdf
CPS Series
https://iseq-hv.com/en/products/detail/CPS
Archives
https://iseq-hv.com/download/?dir=DC_DC/CPS/archive

Manufacturers website (connectors)	
Radiall	https://www.radiall.com/
Rosenberger	https://www.rosenberger.com/
GES electronic	https://www.ges-highvoltage.com/

9. Glossary

SHORTCUT	MEANING
V_{nom}	nominal output voltage
V_{out}	output voltage
V_{set}	set value of output voltage
V_{mon}	monitor voltage of output voltage
V_{meas}	digital measured value of output voltage
V_{p-p}	peak to peak ripple voltage
V_{in}	input / supply voltage
V_{type}	type of output voltage (AC, DC)
V_{ref}	internal reference voltage
V_{max}	limit (max.) value of output voltage
$\Delta V_{out} - [\Delta V_{in}]$	deviation of V_{out} depending on variation of supply voltage
$\Delta V_{out} - [\Delta R_{load}]$	deviation of V_{out} depending on variation of output load
V_{bounds}	voltage bounds, a tolerance tube $V_{set} \pm V_{bounds}$ around V_{set}
I_{nom}	nominal output current
I_{out}	output current
I_{set}	set value of output current
I_{mon}	monitor voltage of output current
I_{meas}	digital measured value of current
I_{trip}	current limit to shut down the output voltage
I_{in}	input / supply current
I_{max}	limit (max.) value of output current
I_{limit}	current limit
I_{bounds}	current bounds, a tolerance tube $I_{set} \pm I_{bounds}$ around I_{set}
P_{nom}	nominal output power
P_{in}	input power
P_{in_nom}	nominal input power
T	temperature
T_{REF}	reference temperature
ON	HV ON
OFF	HV OFF
CH	channel(s)
HV	high voltage
LV	low voltage
GND	signal ground
INH	Inhibit
POL	Polarity
KILL	KillEnable

10. Warranty & Service

This device is made with high care and quality assurance methods. The standard factory warranty is 12 months. Please contact the iseg sales department if you wish to extend the warranty.

CAUTION!



CAUTION!

Repair and maintenance may only be performed by trained and authorized personnel.

For repair please follow the RMA instructions on our website: www.iseg-hv.com/en/support/rma

11. Disposal

INFORMATION



INFORMATION

All high-voltage equipment and integrated components are largely made of recyclable materials. Do not dispose the device with regular residual waste. Please use the recycling and disposal facilities for electrical and electronic equipment available in your country.

12. Manufacturer contact

iseq Spezialelektronik GmbH

Bautzner Landstr. 23

01454 Radeberg / OT Rossendorf

GERMANY

FON: +49 351 26996-0 | FAX: +49 351 26996-21

www.iseg-hv.com | info@iseg-hv.de | sales@iseg-hv.de