

Technical documentation

Last changed on: 2023-08-09

DPS mini series

High Precision Built-in High Voltage Power Supply Module

- Versions from 500 V – 10 kV
- patented resonance converter technology
- INHIBIT
- very low ripple and noise, low EMI
- high precision, high stability



Document history

Version	Date	Major changes
1.2	2023-08-09	the high voltage cable connection is discontinued, document for HV connectors and cables added
1.1	2023-05-04	Adjustment of the internal connection of supply ground and signal ground, Module name contains only voltage, current and polarity, Dimension drawing with projection (ISO), examples in "Order Options" revised, Drawing of output cable for modules with HV cable
1.0	2021-12-13	Initial document, documentation separation of the modules DPS series

Disclaimer / Copyright

Copyright © 2023 by iseg Spezialelektronik GmbH / Germany. All Rights Reserved.

This document is under copyright of iseg Spezialelektronik GmbH, Germany. It is forbidden to copy, extract parts, duplicate for any kind of publication without a written permission of iseg Spezialelektronik GmbH. This information has been prepared for assisting operation and maintenance personnel to enable efficient use.

The information in this manual is subject to change without notice. We take no responsibility for any mistake in the document. We reserve the right to make changes in the product design without reservation and without notification to the users. We decline all responsibility for damages and injuries caused by an improper use of the device.





Safety

This section contains important security information for the installation and operation of the device. Failure to follow safety instructions and warnings can result in serious injury or death and property damage.

Safety and operating instructions must be read carefully before starting any operation.

We decline all responsibility for damages and injuries caused which may arise from improper use of our equipment.

Depiction of the safety instructions

DANGER!	
 DANGER!	<p>“Danger!” indicates a severe injury hazard. The non-observance of safety instructions marked as “Danger!” will lead to possible injury or death.</p>
WARNING!	
 WARNING!	<p>“Warning!” indicates an injury hazard. The non-observance of safety instructions marked as “Warning!” could lead to possible injury or death.</p>
CAUTION!	
 CAUTION!	<p>Advices marked as “Caution!” describe actions to avoid possible damages to property.</p>
INFORMATION	
 INFORMATION	<p>Advices marked as “Information” give important information.</p>



Read the manual.



Attention high voltage!



Important information.

Intended Use

The device may only be operated within the limits specified in the data sheet. The permissible ambient conditions (temperature, humidity) must be observed. The device is designed exclusively for the generation of high voltage as specified in the data sheet. Any other use not specified by the manufacturer is not intended. The manufacturer is not liable for any damage resulting from improper use.

Qualification of personnel

A qualified person is someone who is able to assess the work assigned to him, recognize possible dangers and take suitable safety measures on the basis of his technical training, his knowledge and experience as well as his knowledge of the relevant regulations.

General safety instructions

- Observe the valid regulations for accident prevention and environmental protection.
- Observe the safety regulations of the country in which the product is used.
- Observe the technical data and environmental conditions specified in the product documentation.
- You may only put the product into operation after it has been established that the high-voltage device complies with the country-specific regulations, safety regulations and standards of the application.
- The high-voltage power supply unit may only be installed by qualified personnel.

Important safety instructions

WARNING!



WARNING!

To avoid injury of users it is not allowed to open the unit. There are no parts which can be maintained by users inside of the unit. Opening the unit will void the warranty.

WARNING!



WARNING!

The high-voltage cable must be professionally connected to the consumer/ load and the connection insulated with the appropriate dielectric strength. Do not power the consumer/ load outside of its specified range.

WARNING!



WARNING!

Before connecting or disconnecting HV cables or any operation on the HV output or the application, the unit has to be switched off and discharge of residual voltage has to be finished. Depending on application residual voltages can be present for long time periods.

WARNING!



WARNING!

Do not operate the unit in wet or damp conditions.

WARNING!



WARNING!

Do not operate the unit in an explosive atmosphere.

WARNING!



WARNING!

Do not operate the unit if you suspect the unit or the connected equipment to be damaged.

Table of Contents

Document history	2
Disclaimer / Copyright	2
Safety	3
Depiction of the safety instructions	3
Intended Use	4
Qualification of personnel	4
General safety instructions	4
Important safety instructions	5
1. General description	7
2. Overview	7
3. Technical Data	8
3.1. Specifications	8
3.2. Configurations	9
3.3.	9
3.4. Functional description	9
4. Dimensional drawings	10
4.1. Cable assembly for modules with HV cable	12
5. Connectors assignments	13
6. PIN assignments	14
7. Order guides	14
8. Appendix	15
9. Glossary	16
10. Warranty & Service	17
11. Disposal	17
12. Manufacturer contact	17

1. General description

DPS mini modules are highly precise and highly stable analog controlled high voltage power supplies. The modules are available as very compact metal box. DPS mini modules can be used as standalone DC/DC converters. The output voltage is controllable via analog interface with either a potentiometer (internal reference voltage, see chapter 3.4 Functional description) or an analog control voltage. The polarity of standard DPS mini modules is fixed by factory, positive or negative. To protect the connected load the modules are equipped with INHIBIT.

Customized versions can be produced on [request](#).

2. Overview

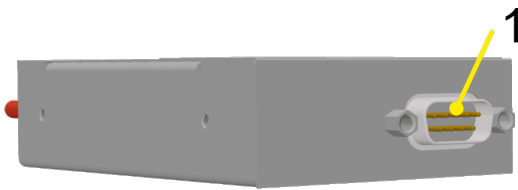

Figure 1: Front view

with HV connector

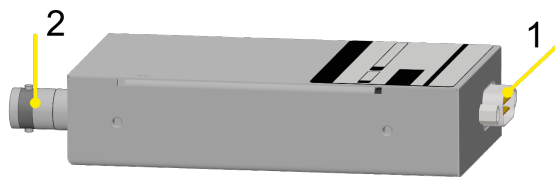

Figure 2: side view

with cable ¹

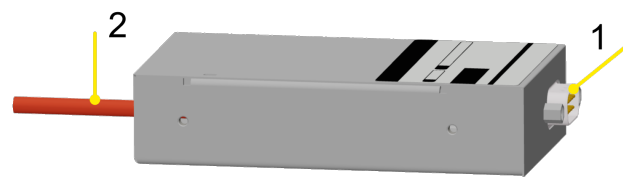

Figure 3: side view

Number	Description	Description	Detailed explanation in chapter
[1]	Interface connector	Power supply and control signal	6 PIN assignments
[2]	High voltage output	depending on model	3.2 Configurations, 5 Connectors assignments

Table 1

1 discontinued

3. Technical Data

3.1. Specifications

SPECIFICATIONS	DPS mini series	
Output voltage V_{nom}	500 V – 10 kV	
Polarity	Factory fixed, positive or negative	
Ripple and noise ($f > 10$ Hz) ¹	typ. < 3 mV _{p-p} max. 10 mV _{p-p}	
Stability – [ΔV_{out} vs. ΔV_{in}] ¹	< $1 \cdot 10^{-5} \cdot V_{nom}$	
Stability – [ΔV_{out} vs. ΔR_{load}] ¹	< $5 \cdot 10^{-5} \cdot V_{nom}$	
Temperatur coefficient	50 ppm/K	
Supply voltage V_{in}	22.8 – 25.2V	
Supply current I_{in}		
at $V_{out} = 0$	< 50 mA	
at $V_{out} = V_{nom}$ / with load	< 600 mA	
Set / Monitor voltage V_{set}	0 – 5 V	
Set / Monitor accuracy	$\pm 1 \% \cdot V_{nom}$	
Voltage ramp up/down	$0.25 \cdot V_{nom} / s$	
Protection	Overload and short circuit protected (ATTENTION: there is only one short circuit or arc per second allowed!) V/I -limits = V_{nom}, I_{nom}	
Remote connector	D-Sub 9, Figure 12	
HV connector	SHV	
Case	metal box	
Dimensions – L/W/H	≤ 6 kV → 109/ 62.5/ 25 mm ³ ≥ 8 kV to ≤ 10 kV, (cable ²) → 98/ 74/ 22 mm ³ 8 kV, (connector S08) → 98/ 74/ 22 mm ³ 10 kV, (connector S10) → 103/ 74/ 25 mm ³	
Operating temperature	0 °C – 40 °C	
Storage temperature	-20 °C – 85°C	
Humidity	max. 70 %, not condensing	
Notes:		
1) – Specifications for stability, ripple and noise are guaranteed in the range $2\% \cdot V_{nom} < V_{out} \leq V_{nom}; I_{set} \geq 4\% I_{nom}$ for DPS mini		
2) – discontinued		

Table 2: Technical data: Specifications

3.2. Configurations

CONFIGURATIONS DPS mini								
Name	V _{nom}	I _{nom}	Standard Ripple (mV _{p-p})	Internal Capacitance nominal (nF)	Damping Resistor (kOhm)	Discharge Resistor (MOhm)	HV connector	Item Code
DPx 05 156	500 V	15 mA	10	450	0.1	3.3	cable ⁽¹⁾ /SHV	DM005156x2450oooccrk
DPx 10 805	1 kV	8 mA	10	425	0.22	50	cable ⁽¹⁾ /SHV	DM010805x2450oooccrk
DPx 20 405	2 kV	4 mA	10	44	1.0	50	cable ⁽¹⁾ /SHV	DM020405x2450oooccrk
DPx 30 305	3 kV	3 mA	10	33	1.5	50	cable ⁽¹⁾ /SHV	DM030305x2450oooccrk
DPx 40 205	4 kV	2 mA	10	22	1.5	50	cable ⁽¹⁾ /SHV	DM040205x2450oooccrk
DPx 60 105	6 kV	1 mA	10	12	18	200	cable ⁽¹⁾ /S08	DM060105x2450oooccrk
DPx 80 105	8 kV	1 mA	10	5	36	500	cable ⁽¹⁾ /S08	DM080105x2450oooccrk
DPx 100 504	10 kV	0,5 mA	10	4	54	500	cable ⁽¹⁾ /S10	DM100504x2450oooccrk

Notes:
1) – discontinued
replacement characters: o – options, c – connector, r – revision, k – customization, x – polarity fixed (negative/positive)

Table 3: Configurations: DPS mini

3.3.

OPTIONS / ORDER INFO	INFO	EXAMPLE
POLARITY	Positive: x = p	DP p 05 156
	Negative: x = n	DP n 05 156
CABLE ⁽¹⁾		DPp 05 156_ CAB

Notes:
1) - discontinued

Table 4: Technical data: Options and order information

3.4. Functional description

DPS mini modules can be operated as constant voltage or constant current source, depending on the limiting set value (V_{SET} or I_{SET}). The specification for ripple and noise and stability is valid for constant voltage mode only.

Via PIN "INH" the voltage generation is switched on with ramp, but switched off without ramp. A monitor voltage for the output current and output voltage is available via the I_{MON} and V_{MON} connections.

The pin REF (reference, see chapter 5 Connectors assignments) can be used for the V_{SET} voltage via an additional circuit (see Figure 4: VSET)

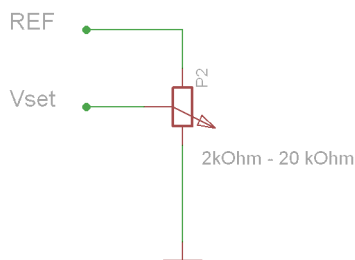
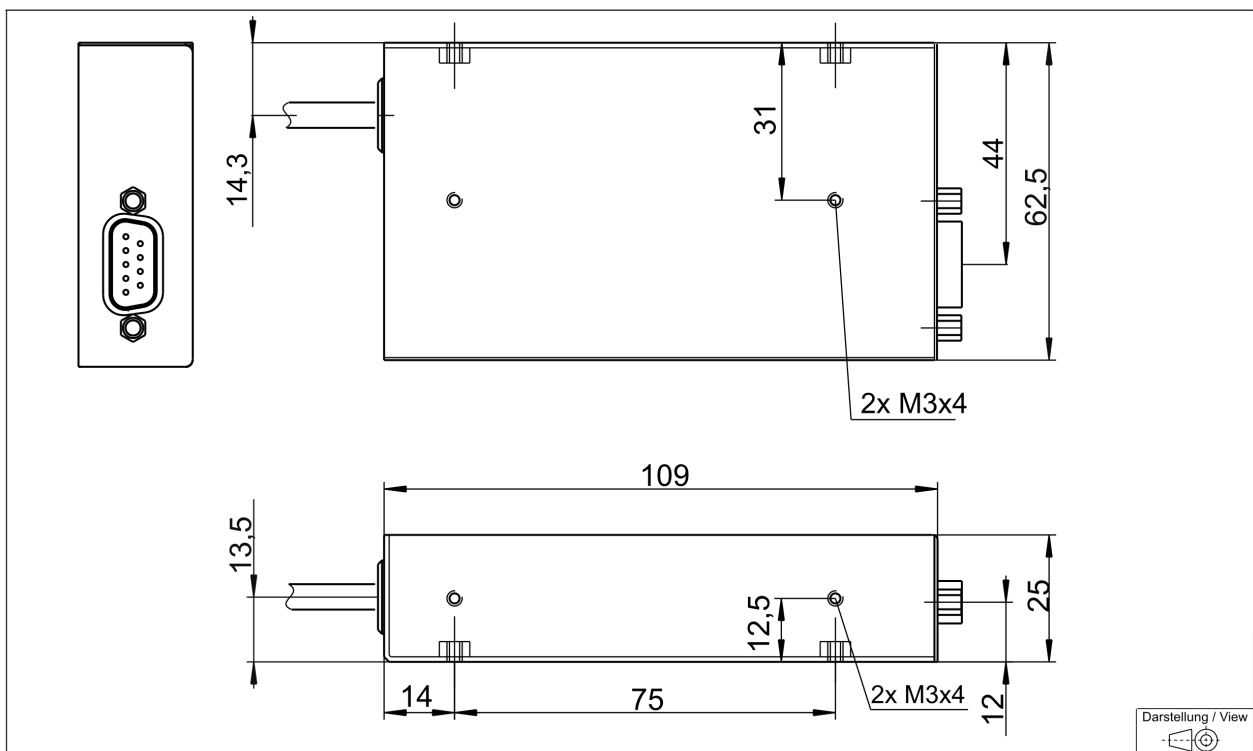
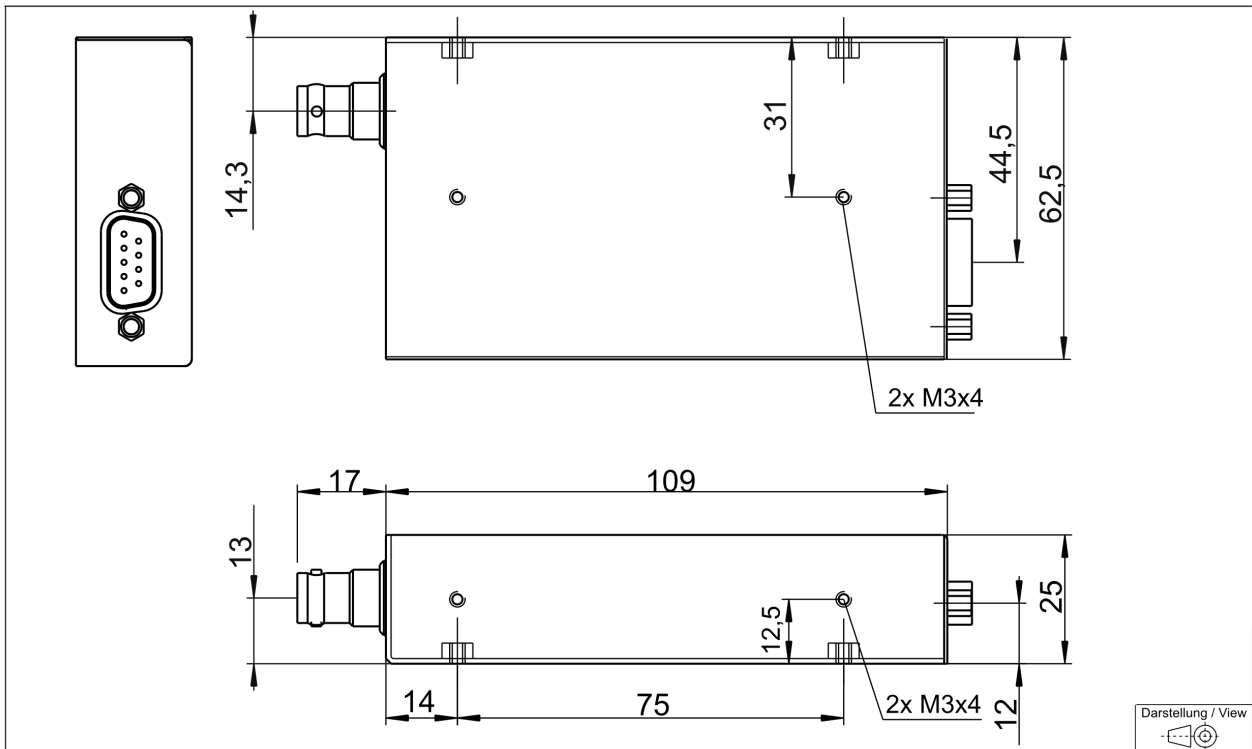

Figure 4: VSET

4. Dimensional drawings



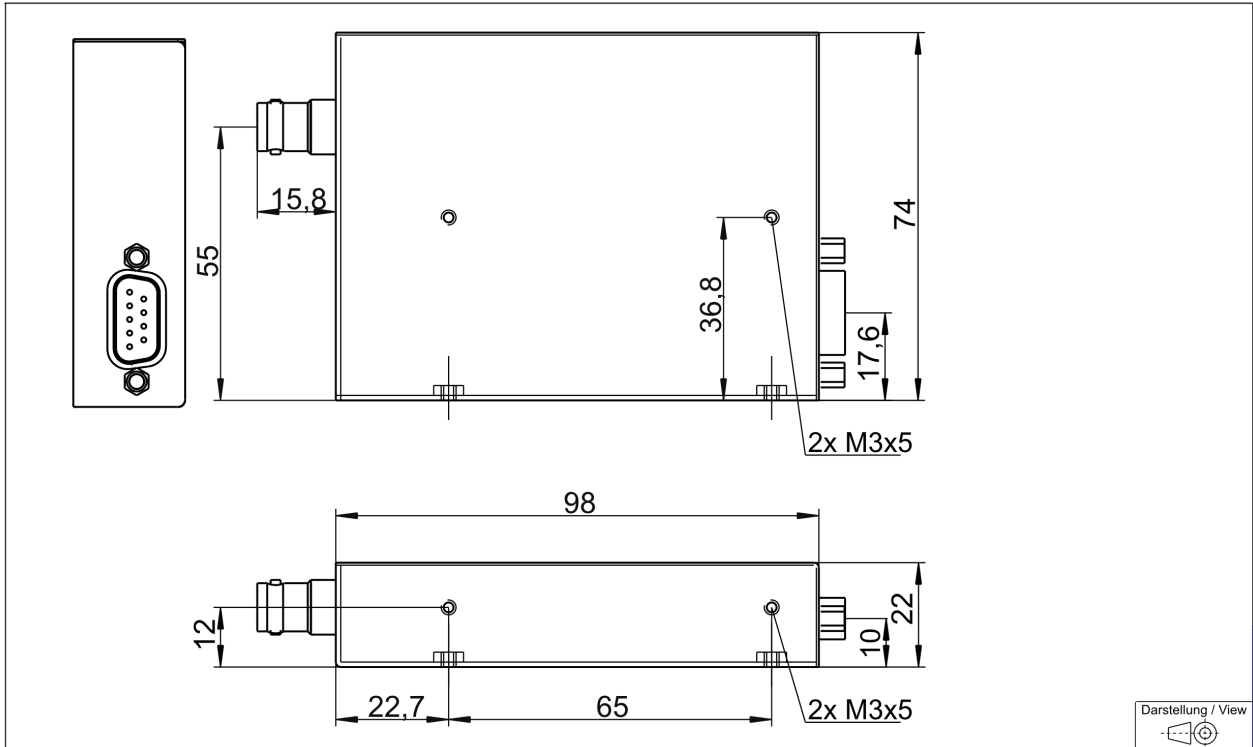

Figure 7: dimensional drawing DPS mini 8kV / HV connectors

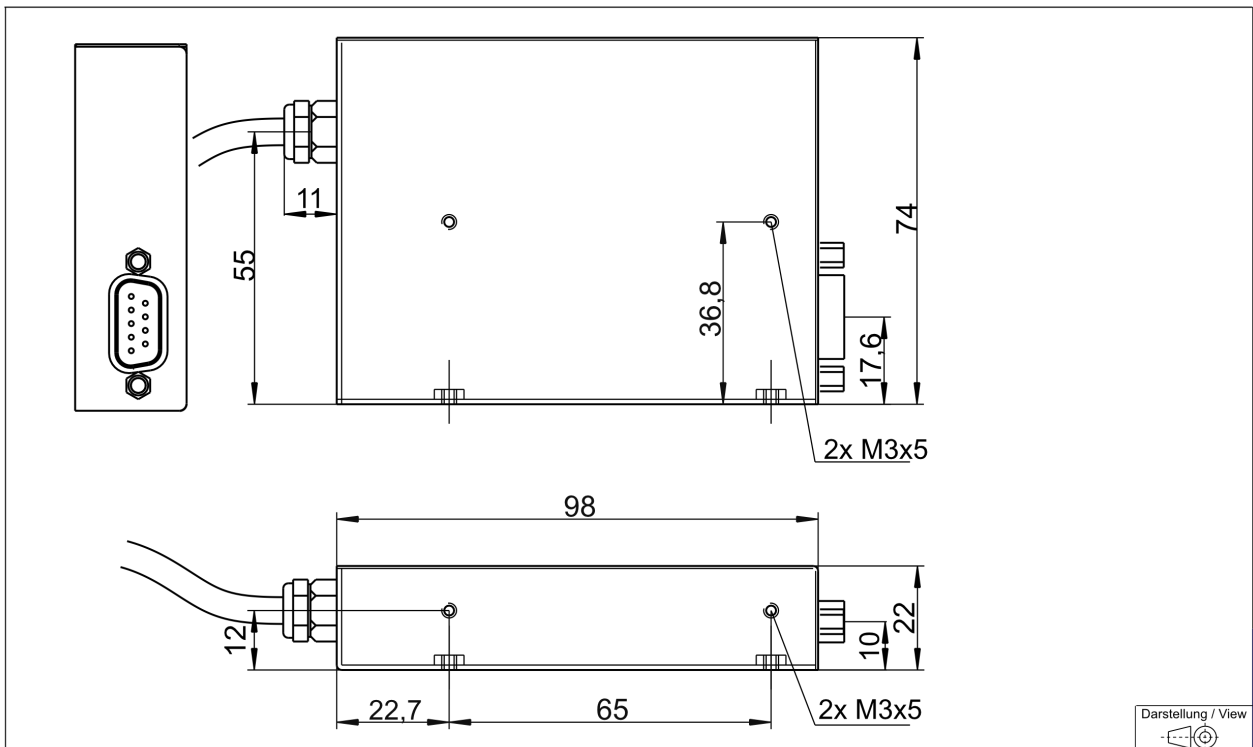

Figure 8: dimensional drawing DPS mini $\geq 8kV$ to $\leq 10kV$ / cable

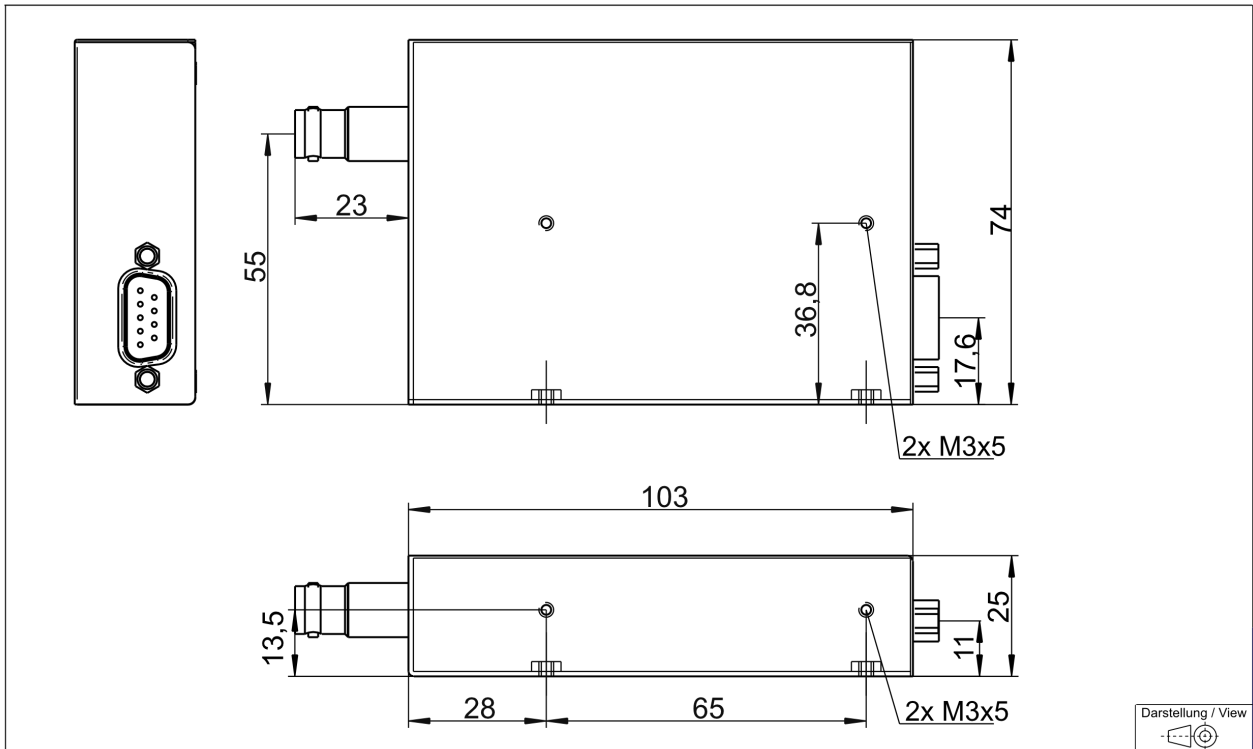

Figure 9: dimensional drawing DPS mini 10kV / HV connectors

4.1. Cable assembly for modules with HV cable

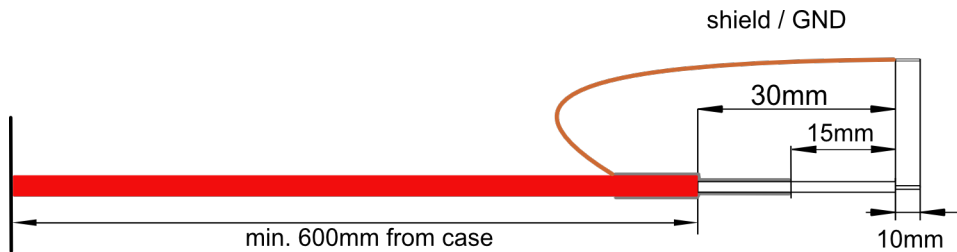

Figure 10: for up to 6 kV modules with CAB (cable)

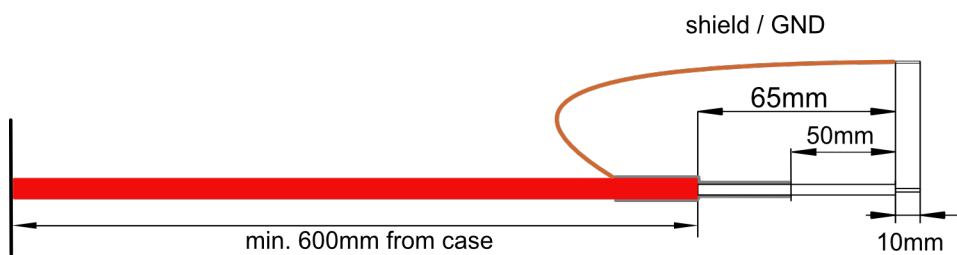

Figure 11: for 8 und 10 kV modules with CAB (cable)

5. Connectors assignments





CONNECTORS – POWER SIDE		PART NUMBERS (manufacturer code / iseg accessory parts item code)	
D-SUB9 - male		CABLE SIDE	
PIN 1  <i>Figure 12</i>	connector	D SUD9	
	manufacturer	various manufacturer	
	iseg part number		
SHV		CABLE SIDE	
 <i>Figure 13</i>	part number	57K101-006N3	
	manufacturer	Rosenberger	more details chapter 8 Appendix
	iseg part number	Z590162	
S08		CABLE SIDE	
 <i>Figure 14</i>	part number	R317.005.000	
	manufacturer	Radiall	more details chapter 8 Appendix
	iseg part number	Z592474	
S10		CABLE SIDE	
 <i>Figure 15</i>	part number	1065-1QD	
	manufacturer	Kings Electronics	more details chapter 8 Appendix
	iseg part number	Z592512	

Table 5: Connectors and PIN assignments

6. PIN assignments

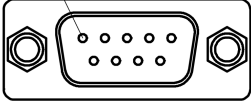
PIN	NAME	DESCRIPTION	VALUE
1	0V ¹⁾	Supply ground	0 V
2	IMON	I _{mon} Monitor voltage of output current	0 ... 5 V
3	INH	Inhibit, LOW = active, shut down the output voltage	TTL-level: LOW → HV OFF HIGH or n.c. → HV ON
4	ISET	I _{set} Set voltage of output current	0 ... 5 V
5	VIN	V _{in} Supply voltage	+24 V DC
6	GND ¹⁾	Signal ground	
7	VMON	V _{mon} Monitor voltage	0 ... 5 V
8	VSET	V _{set} Set value of output voltage	0 ... 5V
9	REF	V _{ref} Internal reference voltage	5 V

Notes:
Case is connected to GND
¹⁾ internally connected for modules with output voltage from 500V to 6kV

Table 6: PIN Assignment D-SUB 9

7. Order guides

CONFIGURATION ORDER GUIDE (item code parts)									
DM	030	405	x	24	50	000	02	0	0
Type	V _{nom}	I _{nom} (nA)	Polarity	Input Voltage	Monitor Voltage	Option	HV-Connector	Revision	Customized Version
DPS mini	three significant digits • 100V For Example: 030 = 3000V	two significant digits + number of zeros For Example: 405 = 4mA	P = positive N = negative	two significant digits For Example: 24 = 24 Volt			00 = Cable ¹⁾ 02 = SHV 03 = S08 04 = S10	one digit 0 = no revision For Example: A = first revision	one digit 0 = no customization

Notes:
1) - discontinued

Table 7: Configuration item code

CABLE ORDER GUIDE					
POWER SUPPLY SIDE CONNECTOR	V _{max}	CABLE CODE	CABLE DESCRIPTION	LOAD SIDE CONNECTOR	ORDER CODE LLL = length in m ¹⁾
SHV	≤ 5 kV	04	HV cable shielded 30kV (HTV-30S-22-2)	open	SHV_C04-LLL
S08	≤ 8 kV	04	HV cable shielded 30kV (HTV-30S-22-2)	open	S08_C04-LLL
S10	≤ 10 kV	04	HV cable shielded 30kV (HTV-30S-22-2)	open	S10_C04-LLL

Notes:
¹⁾ Length building examples: 10cm → 0.1, 2.5m → 2.5, 12m → 012, 999m → 999

Table 8: Guideline for cable ordering

8. Appendix

For more information please use the following download links:

This document
https://iseq-hv.com/download/DC_DC/CPS/iseq_datasheet_DPSmini_en.pdf
DPS mini Series
https://iseq-hv.com/en/products/detail/DPS
Archives
https://iseq-hv.com/download/?dir=DC_DC/DPS/archive
Cables and connectors
https://iseq-hv.com/download/ACCESSORIES/Adapters%20and%20Cables/iseq_Cables%20and%20Connectors_en.pdf

Manufacturers website (connectors)	
Kings Electronics	https://www.winconn.com/
Radiall	https://www.radiall.com/
Rosenberger	https://www.rosenberger.com/

9. Glossary

SHORTCUT	MEANING
V_{nom}	nominal output voltage
V_{out}	output voltage
V_{set}	set value of output voltage
V_{mon}	monitor voltage of output voltage
V_{meas}	digital measured value of output voltage
V_{p-p}	peak to peak ripple voltage
V_{in}	input / supply voltage
V_{type}	type of output voltage (AC, DC)
V_{ref}	internal reference voltage
V_{max}	limit (max.) value of output voltage
$\Delta V_{out} [\Delta V_{in}]$	deviation of V_{out} depending on variation of supply voltage
$\Delta V_{out} [\Delta R_{load}]$	deviation of V_{out} depending on variation of output load
V_{bounds}	Voltage bounds, a tolerance tube $V_{set} \pm V_{bounds}$ around V_{set} .
I_{nom}	nominal output current
I_{out}	output current
I_{set}	set value of output current
I_{mon}	monitor voltage of output current
I_{meas}	digital measured value of current
I_{trip}	current limit to shut down the output voltage
I_{in}	input / supply current
I_{max}	limit (max.) value of output current
I_{limit}	Current Limit.
I_{bounds}	Current bounds, a tolerance tube $I_{set} \pm I_{bounds}$ around I_{set} .
P_{nom}	nominal output power
P_{in}	input power
P_{in_nom}	nominal input power
T	temperature
T_{REF}	Reference temperature
ON	HV ON/OFF
/ON	HV OFF/ON
CH	channel(s)
HV	high voltage
LV	low voltage
GND	signal ground
INH	Inhibit
POL	Polarity
KILL	KillEnable

10. Warranty & Service

This device is made with high care and quality assurance methods. The standard factory warranty is 12 months. Please contact the iseg sales department if you wish to extend the warranty.

CAUTION!



CAUTION!

Repair and maintenance may only be performed by trained and authorized personnel.

For repair please follow the RMA instructions on our website: www.iseg-hv.com/en/support/rma

11. Disposal

INFORMATION



INFORMATION

All high-voltage equipment and integrated components are largely made of recyclable materials. Do not dispose the device with regular residual waste. Please use the recycling and disposal facilities for electrical and electronic equipment available in your country.

12. Manufacturer contact

iseq Spezialelektronik GmbH

Bautzner Landstr. 23

01454 Radeberg / OT Rossendorf

GERMANY

FON: +49 351 26996-0 | FAX: +49 351 26996-21

www.iseg-hv.com | info@iseg-hv.de | sales@iseg-hv.de