

Technical documentation

Last changed on: 2021-09-28

EPS series

Versatile Built-in or System Capable High Voltage Power Supply Module

- Versions from 500V – 30 kV
- 60 W and 150 W versions
- patented resonance converter technology
- high efficiency
- available as metal-box or 3U MMC (only 60 W) version
- combinable in a multichannel THQ AC/DC HV power supply
- voltage and current control
- low ripple and noise, low EMI
- multiple options (INTERLOCK, ARC, CLD)
- customized versions on request



Document history

Version	Date	Major changes
3.2	2021-09-28	Improved description: Item code 3UC modules, HV connector configuration, new dimensions
3.1	2021-03-31	Improved description, Item code revision and customization,
3.0	2020-12-02	Improved description, Corrections due to circuit changes
2.0	2017-02-28	Relayouted documentation

Disclaimer / Copyright

Copyright © 2021 by iseg Spezialelektronik GmbH / Germany. All Rights Reserved.

This document is under copyright of iseg Spezialelektronik GmbH, Germany. It is forbidden to copy, extract parts, duplicate for any kind of publication without a written permission of iseg Spezialelektronik GmbH. This information has been prepared for assisting operation and maintenance personnel to enable efficient use.

The information in this manual is subject to change without notice. We take no responsibility for any mistake in the document. We reserve the right to make changes in the product design without reservation and without notification to the users. We decline all responsibility for damages and injuries caused by an improper use of the device.

Safety

This section contains important security information for the installation and operation of the device. Failure to follow safety instructions and warnings can result in serious injury or death and property damage.

Safety and operating instructions must be read carefully before starting any operation.

We decline all responsibility for damages and injuries caused which may arise from improper use of our equipment.

Depiction of the safety instructions

DANGER!



DANGER!

“Danger!” indicates a severe injury hazard. The non-observance of safety instructions marked as “Danger!” will lead to possible injury or death.

WARNING!



WARNING!

“Warning!” indicates an injury hazard. The non-observance of safety instructions marked as “Warning!” could lead to possible injury or death.

CAUTION!



CAUTION!

Advice marked as “Caution!” describe actions to avoid possible damages to property.

INFORMATION



INFORMATION

Advice marked as “Information” give important information.



Read the manual.



HIGH VOLTAGE

Attention high voltage!



Important information.

Intended Use

The device may only be operated within the limits specified in the data sheet. The permissible ambient conditions (temperature, humidity) must be observed. The device is designed exclusively for the generation of high voltage as specified in the data sheet. Any other use not specified by the manufacturer is not intended. The manufacturer is not liable for any damage resulting from improper use.

Qualification of personnel

A qualified person is someone who is able to assess the work assigned to him, recognize possible dangers and take suitable safety measures on the basis of his technical training, his knowledge and experience as well as his knowledge of the relevant regulations.

General safety instructions

- Observe the valid regulations for accident prevention and environmental protection.
- Observe the safety regulations of the country in which the product is used.
- Observe the technical data and environmental conditions specified in the product documentation.
- You may only put the product into operation after it has been established that the high-voltage device complies with the country-specific regulations, safety regulations and standards of the application.
- The high-voltage power supply unit may only be installed by qualified personnel.

Important safety instructions

DANGER!



DANGER!

Before operations at the load or the high voltage output of the power supply are started, the device has to be switched off, the discharge of residual voltage has to be finished and the high voltage output of the power supply must be properly grounded. Depending on application residual voltages can be present for long time periods. These residual voltages can lead to severe injuries.

DANGER!



DANGER!

High-voltage power supplies of the EPS device class are supplied by a DC voltage of 24 V and generate an output voltage of up to 30 kV. Failure to observe these voltage conditions may result in death, serious injury and/or property damage.

WARNING!



WARNING!

To avoid injury of users it is not allowed to open the unit. There are no parts which can be maintained by users inside of the unit. Opening the unit will void the warranty.

WARNING!



WARNING!

The high-voltage cable must be professionally connected to the load and the connection insulated with the appropriate dielectric strength. Do not power the load of its specified range.

WARNING!



WARNING!

Before connecting or disconnecting HV cables or any operation on the HV output or the application, the unit has to be switched off and discharge of residual voltage has to be finished. Depending on application residual voltages can be present for long time periods.

WARNING!



WARNING!

Do not operate the unit in wet or damp conditions.

WARNING!



WARNING!

Do not operate the unit in an explosive atmosphere.

WARNING!



WARNING!

Do not operate the unit if you suspect the unit or the connected equipment to be damaged.

CAUTION!



Caution!

When the unit is integrated in a system which is controlled by software (THQ, MMC), make sure that nobody is near the high voltage or can be injured.

CAUTION!



CAUTION!

A specified air flow rate (see chapter 2 Technical Data) has to be guaranteed under any circumstances. The air inlet and outlet openings must not be covered or obstructed.

CAUTION!



CAUTION!

The devices (3UC) must only be used in combination with iseg approved crates.

INFORMATION



INFORMATION

The shield of the high voltage output is always connected to the housing and can be used as a return conductor.

Table of Contents

Document history	2
Disclaimer / Copyright	2
Safety	3
Depiction of the safety instructions	3
Intended Use	4
Qualification of personnel	4
General safety instructions	4
Important safety instructions	5
1 General description	9
2 Technical Data	10
2.1 Configurations EPS 60W	11
2.2 Configurations EPS 150W	13
2.3 Options and Order Information	14
3 Functional description	15
3.1 Electrical wiring of the high voltage output	15
3.2 Monitoring	16
3.2.1 Voltage	16
3.2.2 Temperature	17
3.2.3 Switch-on monitoring – EPS 150W	17
3.3 Operation states	18
3.4 Special Functions	19
3.4.1 Low-overshoot charging of capacitors	19
3.4.2 Interlock EPS 150W	19
3.4.3 Ramp	19
3.4.4 INHIBIT	20
3.4.5 ARC Management	20
Devices without option ARC	20
Devices with Option ARC	21
3.4.6 VLN	21
3.4.7 CAR	21
3.5 Analogue I/O interface (AIO)	22
3.5.1 Interface connector D-SUB 9 (EPS metal box)	22
3.5.2 System connector H15 (EPS 3UC)	23
3.5.3 Reference	24
3.5.4 Set values	24
3.5.5 Monitor voltages	24
3.5.6 ON	24
3.6 Connector assignment	26
3.6.1 DC Supply, metal box	26
3.6.2 DC Supply, 3UC	26
3.6.3 High voltage connection	27
3.6.4 AIO connection	27
3.7 Troubleshooting	28
3.8 Maintenance	28
4 Dimensional drawings	29
5 Ground bolt connection	32
6 Connectors and PIN assignments	33
7 Order guides	35

8 Appendix	36
9 Glossary	37
10 Warranty & Service	38
11 Disposal	38
12 Manufacturer contact	38

1 General description

EPS modules are versatile DC/DC high voltage power supplies with multiple options. The modules are available as compact metal box in 60W and 150W version or system capable in 3U Euro cassettes in 60W. EPS modules can be used as standalone DC/DC converters, combined to multichannel AC/DC supply in a THQ series or integrated in a modular MMC system. The output voltage and current can be controlled and monitored via an analogue interface. The modules are equipped with INHIBIT and INTERLOCK (optional).

The patented resonance converter technology and metal box shielding guarantee lowest electromagnetic interference. To fit best in different applications EPS modules can be equipped with ARC management or as capacitor charger with very low output voltage overshoot (option CLD).

Customized versions can be produced on request.

2 Technical Data

SPECIFICATIONS	EPS 60W	EPS 3U	EPS 150W	EPS 60W CLD	EPS 150W CLD
Output voltage V_{nom}	500 V – 30 kV	500 V – 20 kV	1 kV – 30 kV	500 V – 30 kV	1 kV – 30 kV
Polarity	Factory fixed, positive or negative				
Stability	$\Delta V_{out} < 0.05\% \cdot V_{nom}$, after 0.5 h warmup for 8 h				
Voltage regulation ⁽¹⁾ – [ΔV_{out} vs. ΔV_{in}]	$\Delta V_{out} < 0.01\% \cdot V_{nom}$				
Voltage Regulation ⁽¹⁾ – [ΔV_{out} vs. ΔR_{load}]	$\Delta V_{out} < 0.02\% \cdot V_{nom}$				
Current regulation ⁽¹⁾ – [ΔI_{out} vs. ΔV_{in}], [ΔI_{out} vs. ΔR_{load}]	$\Delta I_{out} < 0.02\% \cdot I_{nom}$				
Temperatur coefficient	100 ppm/K				
Supply voltage V_{in}	22.8 V – 26.4 V	22.8 V – 26.4 V	21 V – 29 V	22.8 V – 26.4 V	21 V – 29 V
Supply current I_{in}	< 3.5 A	< 3.5 A	< 9 A	< 3.5 A	< 9 A
Set / Monitor voltage V_{set}	0 - 5 V opt. 0 - 10 V				
Set / Monitor accuracy	$\pm 1\% \cdot V_{nom}$				
CLD Repeat accuracy	$< 0.01 \cdot V_{out}$				
Voltage ramp up/down	0.25 · V_{nom} / s			< 50 ms to V_{nom}	
Protection	Overload and short circuit protected, INHIBIT, over voltage / over temp protection				
Interlock	optional				
Cooling	Convection cooling must be sufficient under load conditions		Forced cooling with integrated fan	Convection cooling must be sufficient under load conditions Forced cooling with integrated fan	
2-pin screw terminal	PWR_+ 24V PWR_0V (internally connected with 0V and GND potential)				
Remote connector	D-Sub 9	H15	D-Sub 9		
HV connector	HV-cable	SHV GES	HV-cable		
Case	metal box	3U cassette	metal box		
Dimensions – L/W/H	185/108/57 mm ³	60.96mm/12HP/3U	170/188/60 mm ³	185/108/57 mm ³	170/188/60 mm ³
Operating temperature	-20 – 50 °C		-20 – 65 °C	-20 – 50 °C	-20 – 65 °C
Storage temperature	-20 – 85 °C		-20 – 85 °C	-20 – 85 °C	-20 – 85 °C
Humidity	20% – 90%, non-condensing				
Notes:	¹⁾ Specifications for stability, regulation, ripple and noise are guaranteed in the range $2\% \cdot V_{nom} < V_{out} \leq V_{nom}$				

Table 1: Technical data

2.1 Configurations EPS 60W

CONFIGURATIONS EPS 60W – compact metal box									
	V _{nom}	I _{nom}	Standard Ripple (V _{p-p})	Internal Capacitance nominal (nF)	Damping Resistor (kOhm)	Discharge Resistor (MOhm)	HV connector	Item code	Options ¹⁾
EPx 05 127 24 y	500 V	120 mA	0.1	3000	0.02	5	cable	EP005127x24zzoooccrk	ARC, A0
EPx 10 606 24 y	1 kV	60 mA	0.1	1200	0.1	55	cable	EP010606x24zzoooccrk	ARC, A0
EPx 15 406 24 y	1.5 kV	40 mA	0.1	750	0.1	55	cable	EP015406x24zzoooccrk	ARC, A0
EPx 20 306 24 y	2 kV	30 mA	0.2	600	0.1	55	cable	EP020306x24zzoooccrk	ARC, A0
EPx 30 206 24 y	3 kV	20 mA	0.5	140	1	55	cable	EP030206x24zzoooccrk	ARC, A0
EPx 40 156 24 y	4 kV	15 mA	2	64	1	55	cable	EP040156x24zzoooccrk	ARC, A0
EPx 50 126 24 y	5 kV	12 mA	2.5	64	1.4	500	cable	EP050126x24zzoooccrk	ARC, A0
EPx 60 106 24 y	6 kV	10 mA	0.5	64	3.6	500	cable	EP060106x24zzoooccrk	ARC, A0
EPx 80 705 24 y	8 kV	7 mA	4	22	9	500	cable	EP080705x24zzoooccrk	ARC, A0
EPx 100 605 24 y	10 kV	6 mA	1	22	9	500	cable	EP100605x24zzoooccrk	ARC, A0
EPx 150 405 24 y	15 kV	4 mA	120	6,8	13.5	330	cable	EP150405x24zzoooccrk	ARC, A0
EPx 200 305 24 y	20 kV	3 mA	400	3	55	330	cable	EP200305x24zzoooccrk	ARC, A0
EPx 300 205 24 y	30 kV	2 mA	500	2.2	68	330	cable	EP300205x24zzoooccrk	ARC, A0

Notes:
¹⁾ – ARC and 10V monitor not combinable

replacement characters: o – options, c – connector, r – revision, k – customization, z – monitor voltage item code, x – polarity (P=positive/N=negative), y – monitor voltage, see 2.3 Options and Order Information

Table 2: Configurations EPS 60W – compact metal box

CONFIGURATIONS EPS 60 W – 3UC Euro cassette									
	V _{nom}	I _{nom}	Standard Ripple (V _{p-p})	Internal Capacitance nominal (nF)	Damping Resistor (kOhm)	Discharge Resistor (MOhm)	HV connector	Item code	Options
EPx 05 127 24 y	500 V	120 mA	0.1	3000	0.02	5	SHV	EK005127x2450oooccrk	ARC
EPx 10 606 24 y	1 kV	60 mA	0.1	1200	0.1	55	SHV	EK010606x2450oooccrk	ARC
EPx 15 406 24 y	1.5 kV	40 mA	0.1	750	0.1	55	SHV	EK015406x2450oooccrk	ARC
EPx 20 306 24 y	2 kV	30 mA	0.2	600	0.1	55	SHV	EK020306x2450oooccrk	ARC
EPx 30 206 24 y	3 kV	20 mA	0.5	140	1	55	SHV	EK030206x2450oooccrk	ARC
EPx 40 156 24 y	4 kV	15 mA	2	64	1	55	SHV	EK040156x2450oooccrk	ARC
EPx 50 126 24 y	5 kV	12 mA	2.5	64	1.4	500	SHV	EK050126x2450oooccrk	ARC
EPx 60 106 24 y	6 kV	10 mA	0.5	64	3.6	500	S08	EK060106x2450oooccrk	ARC
EPx 80 705 24 y	8 kV	7 mA	4	22	9	500	G11	EK080705x2450oooccrk	ARC
EPx 100 605 24 y	10 kV	6 mA	1	22	9	500	G11	EK100605x2450oooccrk	ARC
EPx 150 405 24 y	15 kV	4 mA	120	6,8	13.5	330	G21	EK150405x2450oooccrk	ARC
EPx 200 305 24 y	20 kV	3 mA	400	3	55	330	G21	EK200305x2450oooccrk	ARC

Notes:
replacement characters: o – options, c – connector, r – revision, k – customization, z – monitor voltage item code, x – polarity (P=positive/N=negative), y – monitor voltage, see 2.3 Options and Order Information

Table 3: Configurations EPS 60W – 3UC Euro cassette

CONFIGURATIONS EPS 60W CLD – compact metal box									
	V _{nom}	I _{nom}	Internal Capacitance		Damping Resistor (kOhm)	Discharge Resistor (MOhm)	HV connector	Item code	Options ⁽¹⁾
			nominal (nF)	at V _{nom} (nF)					
EPx 05 127 24 y CLD	500 V	120 mA	2000	2000	0.11	5	cable	EP005127x24zzCLDccrk	ARC, A0
EPx 10 606 24 y CLD	1 kV	60 mA	220	220	0.4	55	cable	EP010606x24zzCLDccrk	ARC, A0
EPx 15 406 24 y CLD	1.5 kV	40 mA	150	150	1.5	55	cable	EP015406x24zzCLDccrk	ARC, A0
EPx 20 306 24 y CLD	2 kV	30 mA	200	200	1.5	55	cable	EP020306x24zzCLDccrk	ARC, A0
EPx 30 206 24 y CLD	3 kV	20 mA	60	12	2	55	cable	EP030206x24zzCLDccrk	ARC, A0
EPx 40 156 24 y CLD	4 kV	15 mA	24	9	2	55	cable	EP040156x24zzCLDccrk	ARC, A0
EPx 50 126 24 y CLD	5 kV	12 mA	24	6	2.35	500	cable	EP050126x24zzCLDccrk	ARC, A0
EPx 60 106 24 y CLD	6 kV	10 mA	24	5	10.5	500	cable	EP060106x24zzCLDccrk	ARC, A0
EPx 80 705 24 y CLD	8 kV	7 mA	7.6	3.2	13.5	250	cable	EP080705x24zzCLDccrk	ARC, A0
EPx 100 605 24 y CLD	10 kV	6 mA	7.6	2.6	13.5	250	cable	EP100605x24zzCLDccrk	ARC, A0
EPx 150 405 24 y CLD	15 kV	4 mA	6.8	2.8	13.5	330	cable	EP150405x24zzCLDccrk	ARC, A0
EPx 200 305 24 y CLD	20 kV	3 mA	3	1.4	55	330	cable	EP200305x24zzCLDccrk	ARC, A0
EPx 300 205 24 y CLD	30 kV	2 mA	2.2	0.9	68	330	cable	EP300205x24zzCLDccrk	ARC, A0

Notes:
¹⁾ – ARC and 10V monitor not combinable

replacement characters: o – options, c – connector, r – revision, k – customization, z – monitor voltage item code, x – polarity (P=positive/N=negative)
y – monitor voltage, see 2.3 Options and Order Information

Table 4: Configurations EPS 60W CLD – compact metal box

CONFIGURATIONS EPS 60 W CLD – 3UC Euro cassette									
	V _{nom}	I _{nom}	Internal Capacitance		Damping Resistor (kOhm)	Discharge Resistor (MOhm)	HV connector	Item code	Options
			nominal (nF)	at V _{nom} (nF)					
EPx 05 127 24 5 CLD	500 V	120 mA	2000	2000	0.11	5	SHV	EK005127x2450CLDccrk	ARC
EPx 10 606 24 5 CLD	1 kV	60 mA	220	220	0.4	55	SHV	EK010606x2450CLDccrk	ARC
EPx 15 406 24 5 CLD	1.5 kV	40 mA	150	150	1.5	55	SHV	EK015406x2450CLDccrk	ARC
EPx 20 306 24 5 CLD	2 kV	30 mA	200	200	1.5	55	SHV	EK020306x2450CLDccrk	ARC
EPx 30 206 24 5 CLD	3 kV	20 mA	60	12	2	55	SHV	EK030206x2450CLDccrk	ARC
EPx 40 156 24 5 CLD	4 kV	15 mA	24	9	2	55	SHV	EK040156x2450CLDccrk	ARC
EPx 50 126 24 5 CLD	5 kV	12 mA	24	6	2.35	500	SHV	EK050126x2450CLDccrk	ARC
EPx 60 106 24 5 CLD	6 kV	10 mA	24	5	10.5	500	S08	EK060106x2450CLDccrk	ARC
EPx 80 705 24 5 CLD	8 kV	7 mA	7.6	3.2	13.5	250	G11	EK080705x2450CLDccrk	ARC
EPx 100 605 24 5 CLD	10 kV	6 mA	7.6	2.6	13.5	250	G11	EK100605x2450CLDccrk	ARC
EPx 150 405 24 5 CLD	15 kV	4 mA	6.8	2.8	13.5	330	G21	EK150405x2450CLDccrk	ARC
EPx 200 305 24 5 CLD	20 kV	3 mA	3	1.4	55	330	G21	EK200305x2450CLDccrk	ARC

Notes:
replacement characters: c – connector, r – revision, k – customization, x – polarity (P=positive/N=negative)

Table 5: Configurations EPS 60W with Option CLD – 3UC Euro cassette

2.2 Configurations EPS 150W

CONFIGURATIONS EPS 150W										
	V _{nom}	I _{nom}	Standard Ripple (V _{p-p})	VLN Ripple (V _{p-p})	Internal Capacitance nominal (nF)	Damping Resistor (kOhm)	Discharge Resistor (MOhm)	HV connector	Item Code	Option ⁽¹⁾
EPx 10 157 24 y	1 kV	150 mA	0.2	-	1100	0.1	8.5	cable	EP010157x24zzooccrk	ARC, A0
EPx 20 756 24 y	2 kV	75 mA	1	-	600	0.4	8.5	cable	EP020756x24zzooccrk	ARC, A0
EPx 40 406 24 y	4 kV	40 mA	2	-	55	1.0	25	cable	EP040406x24zzooccrk	ARC, A0
EPx 80 206 24 y	8 kV	20 mA	1	-	45	4.0	250	cable	EP080206x24zzooccrk	ARC, A0
EPx 120 126 24 y	12 kV	12.5 mA	2	-	20	4.0	330	cable	EP120126x24zzooccrk	ARC, A0
EPx 150 106 24 y	15 kV	10 mA	1	-	20	4.0	330	cable	EP150106x24zzooccrk	ARC, A0
EPx 200 755 24 y	20 kV	7.5 mA	2	0.75	9.5	10	330	cable	EP200755x24zzooccrk	ARC, A0
EPx 300 505 24 y	30 kV	5 mA	3	1	2.6	10	330	cable	EP300505x24zzooccrk	ARC, A0

Notes:
¹⁾ ARC and 10V monitor cannot be combined
replacement characters: c – connector, r – revision, k – customization, z – monitor voltage item code (5V = 05, 10V = A0), x – polarity (P=positive/N=negative), y – monitor voltage, see 2.3 Options and Order Information

Table 6: Configurations EPS 150W

CONFIGURATIONS EPS 150W CLD										
	V _{nom}	I _{nom}		Internal Capacitance nominal (nF)	Damping Resistor (kOhm)	Discharge Resistor (MOhm)	HV connector	Item code	Option ⁽¹⁾	
EPx 10 157 24 y CLD	1 kV	150 mA		220	0.1	8.5	cable	EP010157x24zzCLDccrk	ARC, A0	
EPx 20 756 24 y CLD	2 kV	75 mA		200	0.1	8.5	cable	EP020756x24zzCLDccrk	ARC, A0	
EPx 40 406 24 y CLD	4 kV	40 mA		14	0.3	25	cable	EP040406x24zzCLDccrk	ARC, A0	
EPx 80 206 24 y CLD	8 kV	20 mA		7.5	1	250	cable	EP080206x24zzCLDccrk	ARC, A0	
EPx 120 126 24 y CLD	12 kV	12.5 mA		3.5	6	330	cable	EP120126x24zzCLDccrk	ARC, A0	
EPx 150 106 24 y CLD	15 kV	10 mA		3.5	6	330	cable	EP150106x24zzCLDccrk	ARC, A0	
EPx 200 755 24 y CLD	20 kV	7.5 mA		2.8	10	330	cable	EP200755x24zzCLDccrk	ARC, A0	
EPx 300 505 24 y CLD	30 kV	5 mA		1.1	10	330	cable	EP300505x24zzCLDccrk	ARC, A0	

Notes:
¹⁾ ARC and 10V monitor cannot be combined
replacement characters: c – connector, r – revision, k – customization, z – monitor voltage item code (5V = 05, 10V = A0), x – polarity (P=positive/N=negative), y – monitor voltage, see 2.3 Options and Order Information

Table 7: Configurations EPS 150W CLD

2.3 Options and Order Information

OPTIONS / ORDER INFO	INFO	EXAMPLE
POLARITY	Positive: x = p , Negative x = n	EP p 05 127 24
Set / monitor voltage	0 – 5V (standard): y = 05 0 – 10V (optional): y = 10	EPp 05 127 24 10
3U – MMC capable version	3UC	
ARC management ⁽¹⁾	ARC	
Capacitor charger	CLD	
Capacitor charger and ARC management ⁽¹⁾	CAR	
VERY LOW NOISE	VLN	
Notes: ¹⁾ for Set/Monitor voltage 5V only		

Table 8: Technical data: Options and order information

3 Functional description

High voltage power supplies of the device class EPS are supplied from a DC voltage and generates a stable output voltage up to the nominal voltage.

The units can be controlled via the specified connector with analogue and digital signals. The INHIBIT function is used to disable and block the generation of high voltage.

In the following, the working principle of the power supply will be described. Next to the DC input there is a EMI/RFI filter, which feeds the DC link. The DC link voltage is buffered by electrolytic capacitors. An inverter with a connected resonance circuit transforms the DC link voltage into a controllable sinusoidal voltage. The HV transformer and HV rectifier provide an output voltage corresponding to the external set voltage. Output voltage and current are measured by high precision voltage dividers and a shunt and are fed back to the control circuit. A damping resistor connected to the output capacitance limits the output current during a load change or ARC.

High voltage power supplies of this class work with a fixed switching frequency. The output parameters are controlled via a pulse width modulation (PWM). The control circuit controls and limits the output voltage and current corresponding to the set values. Normalized monitor voltages for voltage and current are provided for read back. The control circuit is also monitoring the input voltages, auxiliary voltages and the temperatures of cooling air and single components.

Optionally, the device can be equipped with:

- the option capacitor charger (CLD – very low overshoot of the output voltage),
- an interlock safety loop, which safely interrupts the HV generation,
- an ARC management with fixed parameters, which protect the device against overload in the event of permanent arcing,
- lower ripple and noise of the output voltage (VLN – very low noise).

3.1 Electrical wiring of the high voltage output

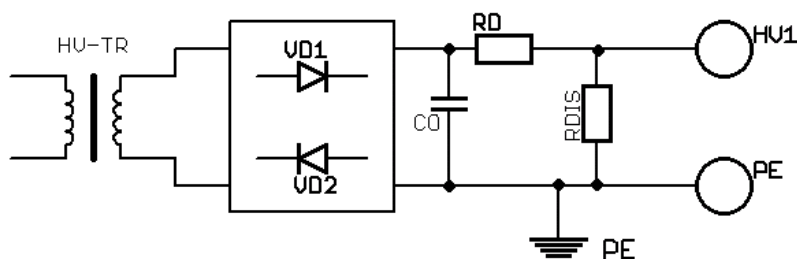

Figure 1: Electrical wiring of the high voltage output

3.2 Monitoring

3.2.1 Voltage

EPS 60W

The supply voltage and the internal auxiliary voltages of this high voltage supply are monitored. If one of these voltages is out of the specified limits, the high voltage generation is stopped.

WARNING!



WARNING!

High voltage generation is reactivated immediately if the limit values are no longer exceeded.

For devices with option capacitor charger, the maximum output voltage value is monitored by the OVP (Over Voltage Protection) comparator. The threshold is set to approx. 106 percent of nominal output voltage. If this threshold is reached (e.g. through an internal defect), high voltage generation is stopped and an error register is set, which blocks the high voltage generation. To reset the error register, the INHIBIT signal must be activated (set low).

EPS 150W

The supply voltage and internal auxiliary voltages of this high voltage supply are monitored for under-voltage and over-voltage. If one of these voltages is out of the specified limits, the high voltage generation is stopped immediately and an error register is set which also blocks the high-voltage generation after re-entering the normal operating range. To reset the error register, INHIBIT must be activated (set to low).

3.2.2 Temperature

60W

Temperature is monitored at several points within the unit. High voltage generation is stopped in case the internal temperature of several modules exceeds a predefined limiting value.

WARNING!



High voltage generation is reactivated immediately if the limit values are no longer exceeded.

150W

The temperature of the inlet air and several modules is monitored in the high-voltage supply. Exceeds the temperature at one of the measuring points the permissible value, the high-voltage generation is stopped immediately and an error register is set. This error register still blocks the high-voltage generation, even if the monitored temperatures are again in their allowed limits. To reset the error register, INHIBIT must be activated (set to low).

3.2.3 Switch-on monitoring – EPS 150W

When the device is switched on by applying the supply voltage, an error register receives a set command for a period of 350 ms. This prevents unwanted high-voltage generation. The error state can only be reset after this time by an activated INHIBIT signal. If operation without the INHIBIT function is desired, e.g. to control the device exclusively with ON, the following options are available:

- INHIBIT is activated by a higher-level circuit after a duration of 350 ms after the supply voltage has been applied and then deactivated, or
- a capacitor with a capacitance of at least 100 μ F is connected between INHIBIT and GND, by which the INHIBIT signal is activated for a period of 400 ms after the supply voltage is applied and is then deactivated
- this function can optionally be disabled at the factory.

3.3 Operation states

The device is remote controlled via the analogue interface. Figure 2: Operating area of the device shows the operating area of the device. There are two modes for high voltage generation:

1. Constant voltage control CV:
Regulation of the output voltage according to the set value of the output voltage under the condition measured output current (I_{MON}) < set value output current (I_{SET}).
2. Constant current control CC:
Regulation of the output current according to the set value of the output current under the condition measured output voltage (V_{MON}) < set value output voltage (V_{SET}).

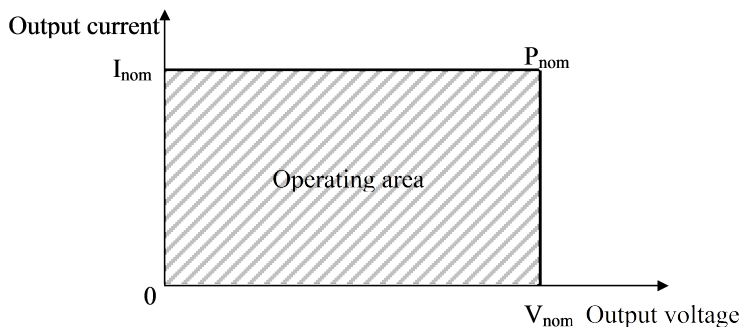

Figure 2: Operating area of the device

3.4 Special Functions

3.4.1 Low-overshoot charging of capacitors

For devices with the CLD option, the internal set value of the output voltage is immediately set to the externally set value after activation of the HV generation. A capacitor connected to the output of the device is charged with the set current up to the specified value of the output voltage.

To minimize the output voltage overshoot, there is a comparator in addition to the voltage control loop, which blocks the HV generation when the output voltage exceeds the set voltage by about $0.5\% \cdot V_{nom}$.

3.4.2 Interlock EPS 150W

Optionally the power supply can be equipped with an interlock, a hardware safety loop. The connector "IL" (maximum cross section area 1.5mm^2) is installed on the front side.

If the loop is closed an internal current source (open circuit voltage 24 V / short circuit current max. 25 mA) will drive a current of ca. 12 mA through a built-in mechanical relays (certified in accordance with IEC/EN 60950 and UL 60950, fulfills the Telcordia requirements according GR 1089 and FCC part 68).

The impedance of the closed loop must be less than 300 Ohm.

If the safety loop is open (Impedance $> 100\text{ kOhm}$), the relays will open. The high voltage generation is stopped only by the opened relay contacts. The relay locks the gate pulses of the semiconductors of the inverter.

It is not possible to switch on the high voltage generation if the safety loop is open.

The state of the opened safety loop is handled as an error. For the release of the high-voltage generating the error register must be reset after closing the safety loop. (see section 3.4.4 INHIBIT)

INFORMATION



INFORMATION

The high voltage cannot be switched on when the safety loop is open.

3.4.3 Ramp

After activating the HV generation, the internal set value of the voltage is increased from zero to the set value with the ramp speed depending on the configuration. If the set current is not reached or exceeded, the output voltage follows this set value ramp. When switching off the HV generation there are 2 cases:

Switching off with ON: The internal set value of the voltage is decreased from the set value to zero with the ramp speed depending on the configuration

Switching off with INHIBIT: The HV generation is interrupted immediately, the set value of the voltage is set to zero.

3.4.4 INHIBIT

By applying a low level signal at pin "INH" of the connector "AIO", the high voltage generation will be shut off immediately and will be blocked. High voltage generation is activated with a high level signal or open contact at pin "INH" of the connector "AIO".

CAUTION!	
 CAUTION!	Do not use the INHIBIT function as a safety loop.

To enable high voltage generation, both signals must enable or disable the HV. The switching states and logic operations are shown in Table 9 Inhibit.

INHIBIT	ON	High Voltage, Function
HV inhibited	HV OFF	OFF, Reset error memory
HV inhibited	HV ON	OFF, Reset error memory
HV not inhibited	HV OFF	OFF
HV not inhibited	HV is switched ON	ON with ramp
HV not inhibited	HV is switched OFF	OFF with ramp
HV will be released	HV ON	ON with ramp
HV will be disabled	HV ON	OFF without ramp, Reset error memory

Table 9: Inhibit

3.4.5 ARC Management

For HV sources in metal box with the optionally ARC management an ARC signal is present at pin "ARC" of the connector "AIO". In the case of an ARC, this signal has a low level for approximately 1 millisecond.

By applying a low level signal at pin "INH" of the connector "AIO" (INHIBIT), the ARC signal also has a low level.

For HV sources in 3UC housing with the ARC management there is no ARC signal.

Devices without option ARC

CAUTION!	
 CAUTION!	For devices without the ARC option, the user must ensure that the permissible number of ARCs is not exceeded. These devices do not protect themselves against high-frequency ARCs.

The permissible number of ARCs depends on the device class, the output voltage as well as the installed options and is specified in Table 10: Permissible number of ARCs.

Device	Number of ARCs / second
EPS without option CLD	1
EPS with option CLD	5

Table 10: Permissible number of ARCs

Devices with Option ARC

The HV power supply is optionally equipped with an ARC Management. Figure 3: ARC Management shows the working principle of the ARC management. The device detects an ARC when the output current is $I_{OUT} = (I_{SET} + 0,5 \cdot I_{NOM})$. After an ARC was detected, the control signals of the inverter are blocked within some μ -seconds for the blanking time

(ARC-Wait, $t_{ARC-Wait} = t_1 - t_0$).

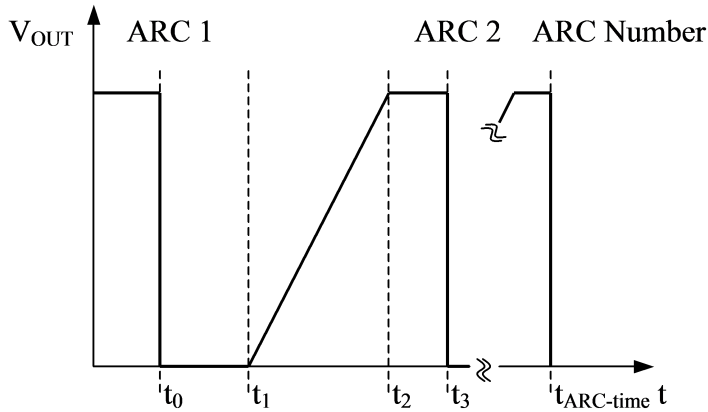

Figure 3: ARC Management

At the same time, the internal set value for the output voltage is set to zero. At the time instance $t = t_1$, the internal set value of the output voltage is increased with the voltage ramp (ARC-Ramp).

For HV sources in metal box with ARC management an ARC signal is present at pin "ARC" of the connector "AIO". In the case of an ARC, this signal has a low level for a approximately 1 millisecond.

HV sources in 3UC housing with ARC management are not equipped with an ARC signal.

The parameters of the ARC-Management are shown in Table 11:Parameters of the ARC Management

	EPS	EPS with option CLD
ARC-Number / second	1	5
ARC-Wait	200 ms \pm 10%	40 ms \pm 10%
ARC-Ramp time	800 ms \pm 10%	160 ms \pm 10%

Table 11: Parameters of the ARC Management

3.4.6 VLN

Reduced ripple see chapter 2 Technical Data.

3.4.7 CAR

CAR is a combination the option ARC-Management and Capacitor Changer.

3.5 Analogue I/O interface (AIO)

All control inputs and outputs are located at the AIO connector. The pin assignment of these connectors is described in the following table.

INFORMATION	
 INFORMATION	The high voltage is turned on/off with the analogue interface control signals "ON" and/or "INHIBIT".

3.5.1 Interface connector D-SUB 9 (EPS metal box)

PIN		DESCRIPTION	VALUE
1		GND	Signal ground
2		IMON	Monitor voltage of output current 0 ... 5 V (opt. 0 ... 10 V) ¹⁾
3		INH	Inhibit, LOW = active, shut down the output voltage TTL-level: LOW → HV OFF HIGH or n.c. → HV ON
4		ISET	Set voltage of output current 0 ... 5 V / (opt. 0 ... 10 V) ⁽¹⁾ , R _i = 10 MOhm
5		ON	HV ON/OFF with voltage ramp TTL-level: LOW → HV ON HIGH or n.c. → HV OFF
6	Without option ARC	GND	Signal ground
	With option ARC	/ARC	Signal ARC TTL level: LOW → ARC (approx. 1 ms) → INH active (low) HIGH → no ARC
7		VMON	Monitor voltage 0 ... 5 V / (opt. 0 ... 10 V) ⁽¹⁾
8		VSET	Set value of output voltage 0 ... 5 V / (opt. 0 ... 10 V) ⁽¹⁾
9		VREF	Internal reference voltage 5 V / (opt. 10 V) ⁽¹⁾
Notes: Case is connected to GND and 0V (Power supply ground) ¹⁾ only without option ARC			

Table 12: PIN Assignment D-SUB 9

3.5.2 System connector H15 (EPS 3UC)

PIN	NAME	DESCRIPTION	VALUE
4	0V ⁽¹⁾	Supply ground	
8	VREF	Internal reference voltage	5 V (opt. 10V)
10	0V ⁽¹⁾	Supply ground	
12	GND ⁽¹⁾	Signal ground	
14	IMON	Monitor voltage of output current	0 ... 5 V (opt. 0 ... 10 V)
16	ON	HV ON/OFF with voltage ramp	TTL-level: LOW → HV ON HIGH or n.c. → HV OFF
20	VSET	Set value of output voltage	0 ... 5 V (opt. 0 ... 10 V)
24	VMON	Monitor voltage	0 ... 5 V (opt. 0 ... 10 V)
26	VIN	Supply voltage	+24 V DC
28	ISET	Set voltage of output current	0 ... 5 V (opt. 0 ... 10 V)
30	KILL_ENA ⁽²⁾	Killenable, high active	TTL-level
32	INH	Inhibit, LOW = active, shut down the output voltage	TTL-level: LOW → HV OFF HIGH or n.c. → HV ON

Notes:
Case is connected to GND
¹⁾ internally connected to GND
²⁾ If KillEnable is active the reaching or exceeding of the I_{set} value will trigger a Kill-signal. This signal will switch off the HV immediately without ramp.

Table 13: PIN Assignment H15 connector

3.5.3 Reference

A reference voltage of 5.05 V (optionally 10.1 V) is available at pin “V_{REF}” of the connector “AIO”. The reference can be used to preset the set values via potentiometers, as shown in Figure 4: Electrical wiring of the analogue and digital in- and outputs. With a total load of 10 kΩ between the reference output and GND the reference voltage at the connector is 5.0 V (10.0 V).

3.5.4 Set values

A voltage between 0 – 5 V¹ at pin “V_{SET}” (reference potential GND) of the connector “AIO” controls the output voltage between 0 – V_{nom}. Similarly, at pin “I_{SET}” the output current is controlled between 0 – I_{nom}. If the Pin “I_{SET}” not connected, the set value is internally set to V_{ref}.

3.5.5 Monitor voltages

Monitor voltages (0 – 5 V¹) proportional to the output voltage and output current are available at pin “V_{MON}” and pin “I_{MON}” of the connector “AIO”, respectively (reference potential GND).

3.5.6 ON

By applying a low level signal at pin “ON” of the connector “AIO”, the high voltage ramps down with the specified voltage ramp speed. After a rising edge of a signal at pin “ON” of the connector “AIO” the output voltage increases with the ramp speed or the given output current to its set value (pin “V_{SET}” of the connector “AIO”) or until the set value of the output current is reached (pin “I_{SET}” of the connector “AIO”, see chapter 3.5 Analogue I/O interface (AIO)).

1 optionally 0 – 10 V

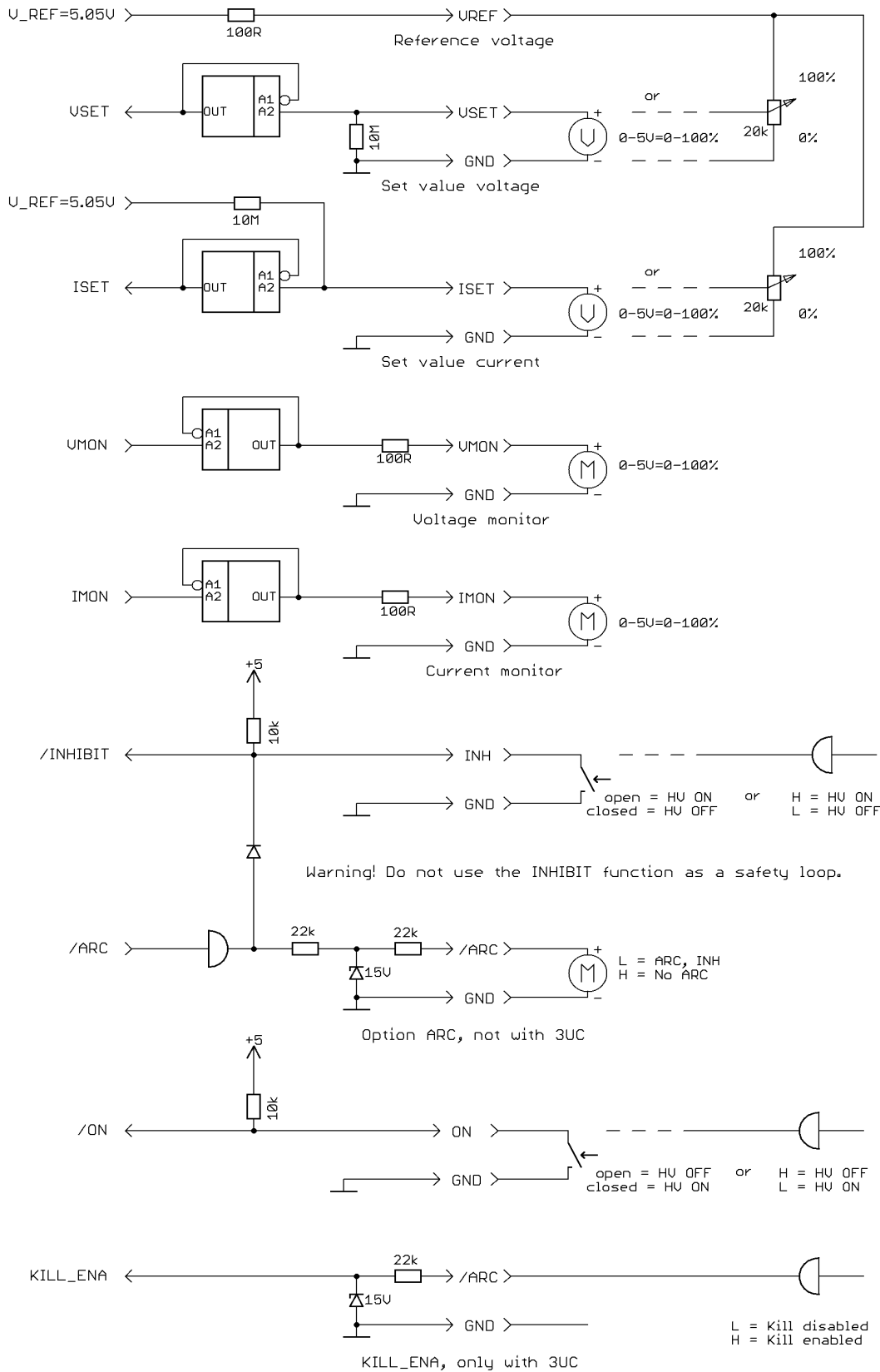

Figure 4: Electrical wiring of the analogue and digital in- and outputs

3.6 Connector assignment

3.6.1 DC Supply, metal box

The device is connected to a DC power supply using the 2 screw terminals on the front of the device (maximum connection cross section 2.5 mm²), which are marked with 0 V or +24 V.

Devices of the 150 W class are equipped with a threaded bolt marked with protective conductor (thread M4). This bolt must be connected to the external protective conductor system (PE) or the local equipotential bonding system.

EPS 60W

+24V GND

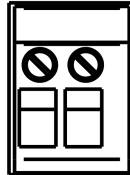

EPS 150W

GND +24V

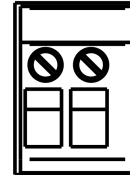

3.6.2 DC Supply, 3UC

The device is connected to a DC power supply using the H15 connector at the corresponding pins (0 V and V_{IN}, see Table 13: PIN Assignment H15 connector).

3.6.3 High voltage connection

The device has one high voltage output.

WARNING!



Before operations at the load or the high voltage output of the power supply are started, the device has to be switched off, the discharge of residual voltage has to be finished and the high voltage output of the power supply must be properly grounded. Depending on application residual voltages can be present for long time periods. These residual voltages can lead to severe injuries.

CAUTION!



The HV cable has to be connected to the load properly and isolated according to proof-voltage.

CAUTION!



The shield of the high voltage output is always connected to the housing and can be used as a return conductor.

CAUTION!



The load current must always be returned directly (screen, separate return conductor) and must not be used for other functions. Due to the galvanic coupling between control, DC supply and GND of the device, high compensation currents can lead to dangerous overvoltages in case of fast discharges (ARCs).

CAUTION!



For the EPS 150W device class a separate conductor with at least 1.5 mm² conductor cross-section can be used as the return conductor. It must be connected to the earthing bolt (see 5 Ground bolt connection) on the rear panel.

3.6.4 AIO connection

See section 3.5 Analogue I/O interface (AIO).

3.7 Troubleshooting

INFORMATION



INFORMATION

If these instructions do not lead to a good result, this unit must be checked by an authorised agent or shipped to the factory.

Trouble	Solution
<ul style="list-style-type: none"> Unit does not provide output voltage. 	→ Check supply voltage Check environmental temperature and cooling conditions Check control Check INHIBIT function
<ul style="list-style-type: none"> External fuses trip during switch on. 	→ Use fuses with slow characteristic (inrush current 25 A)

3.8 Maintenance

Repair and maintenance may only be performed by trained and authorized personnel.

INFORMATION



INFORMATION

For compliance of the specified accuracy of set and monitor signals, the unit has to be recalibrated once a year.

4 Dimensional drawings

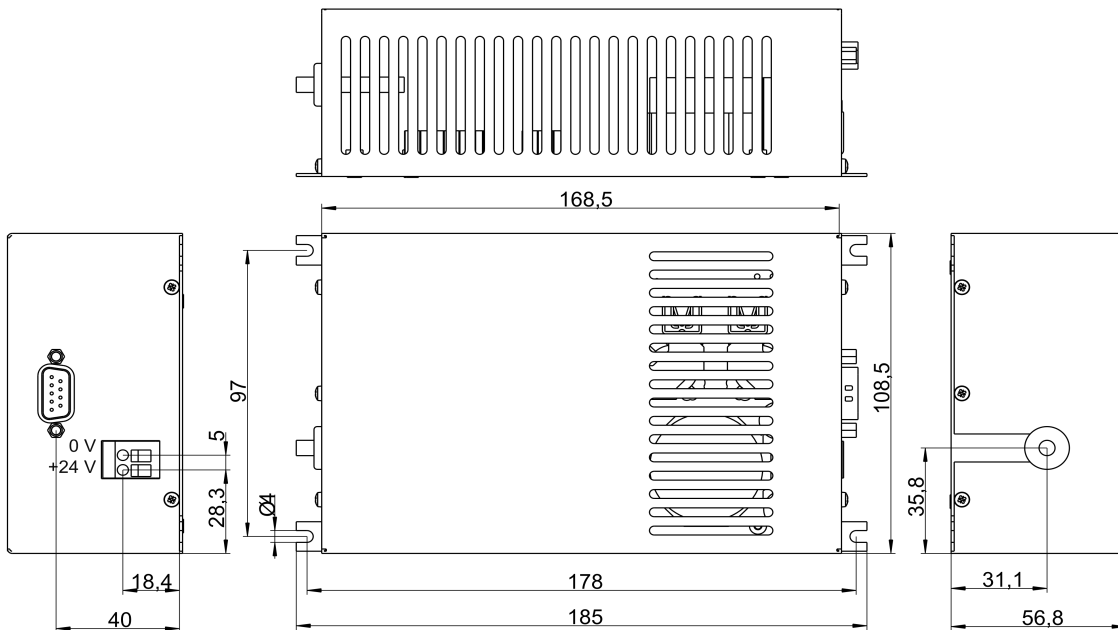

Figure 5: Dimensional drawing EPS 60W Cable

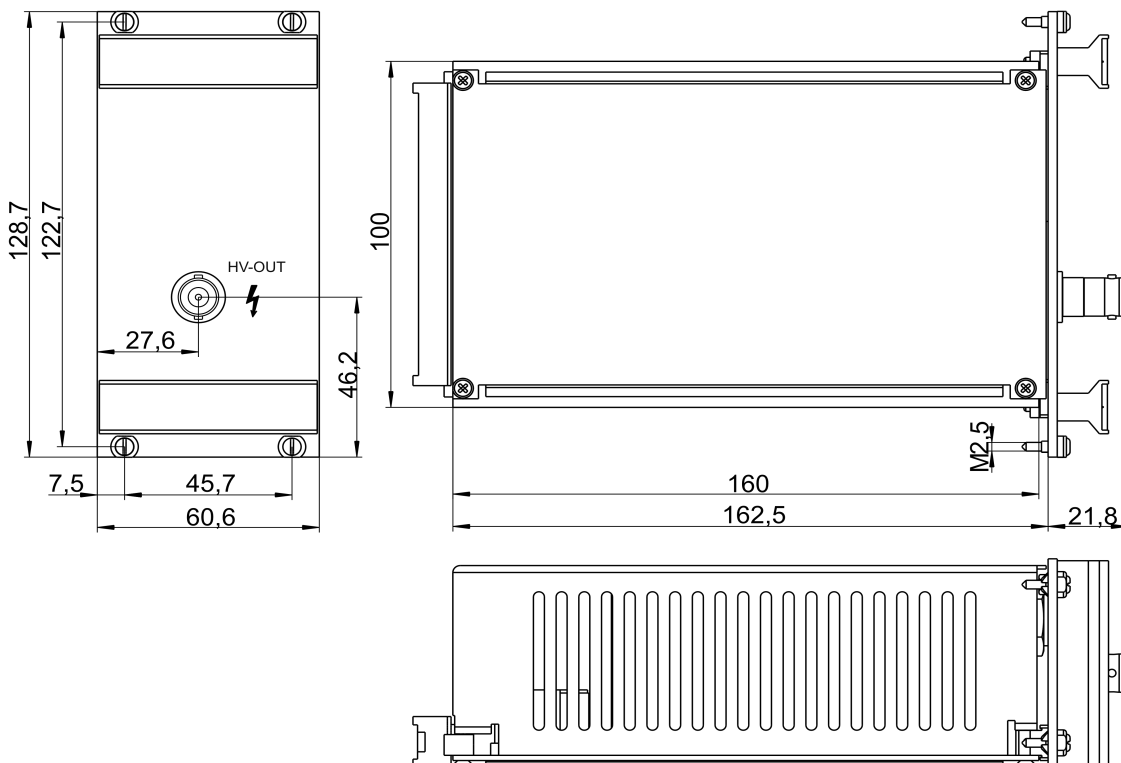

Figure 6: Dimensional drawing EPS 3U Cassette with HV connector $\leq 8kV$

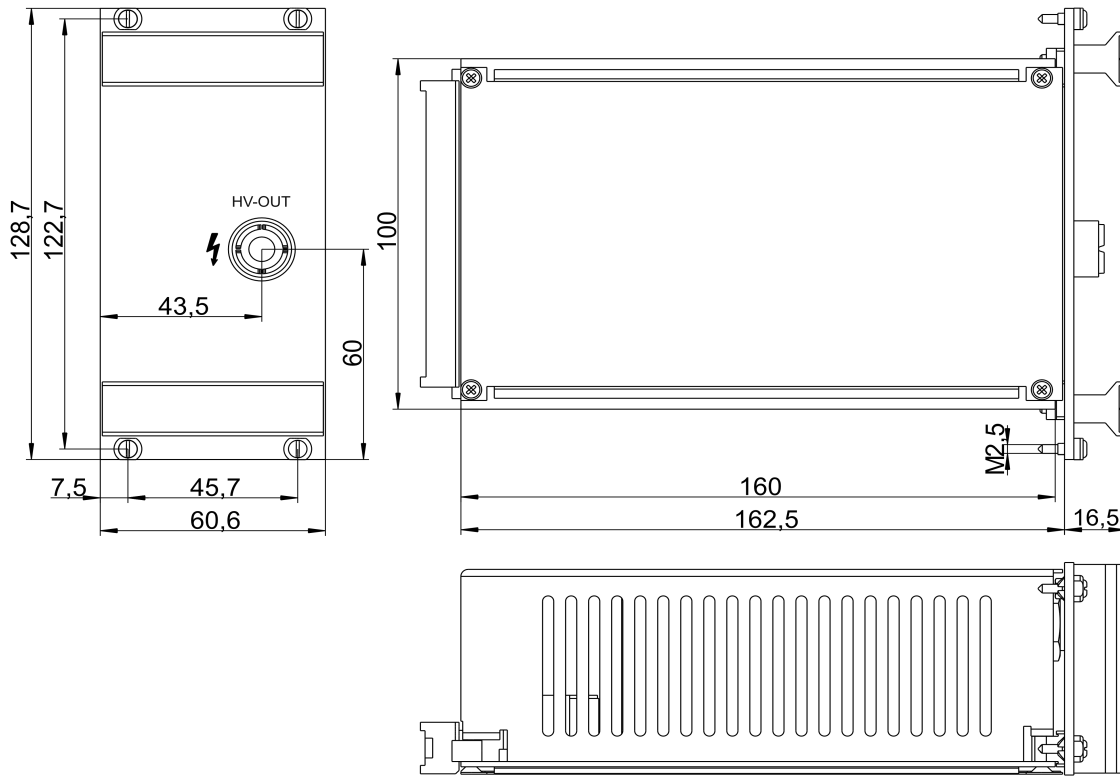

Figure 7: Dimensional drawing EPS 3U Cassette with HV connector ≥ 10 kV

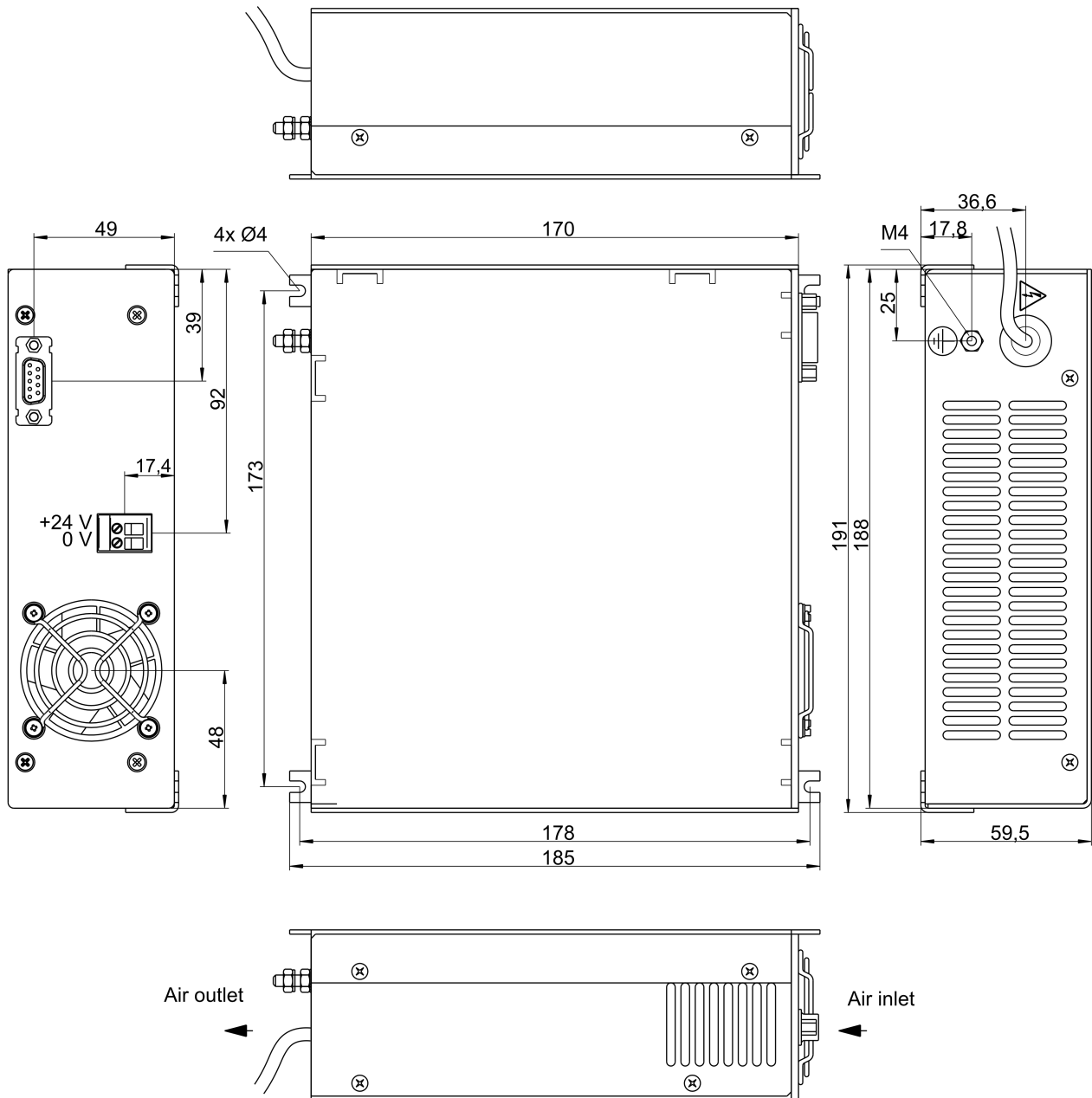

Figure 8: Dimensional drawing EPS 150W

5 Ground bolt connection

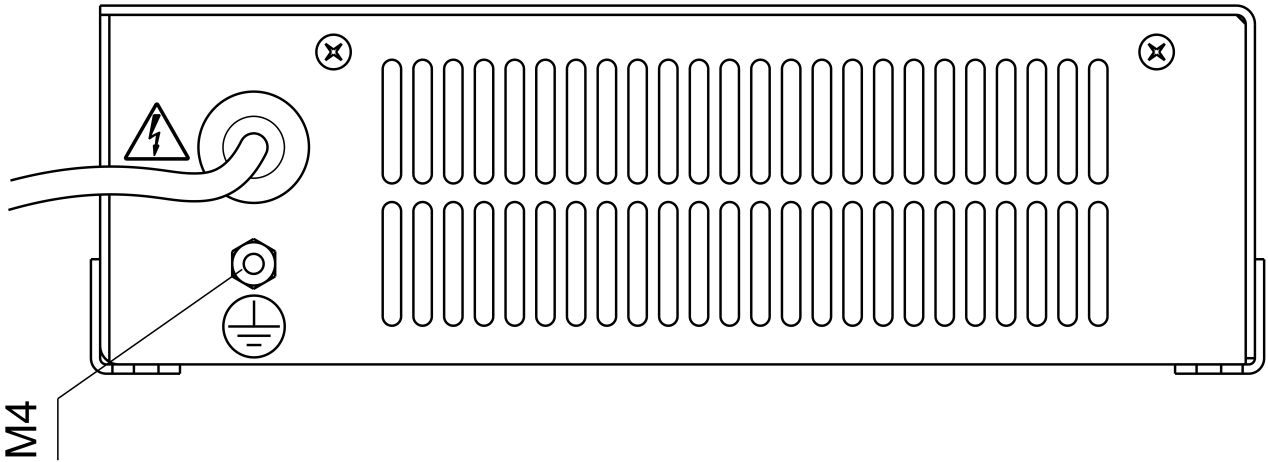

Figure 9: Detail drawing of Figure 8

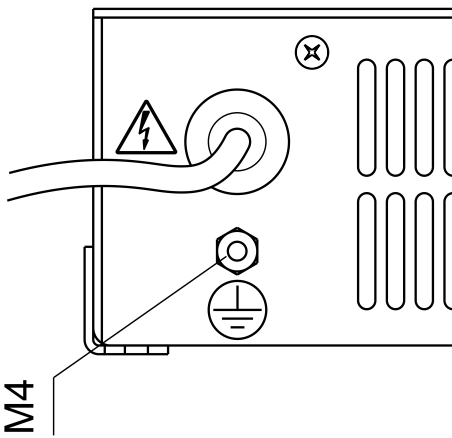







Figure 10: Ground bolt connection

6 Connectors and PIN assignments

CONNECTORS – POWER SIDE		PART NUMBERS (manufacturer code / iseg accessory parts item code)	
SHV		CABLE SIDE	
 Figure 11	part number	57K101-006N3	
	manufacturer	Rosenberger	
	iseg part number	Z590162	
S08		CABLE SIDE	
 Figure 12	part number	R317.005.000	
	manufacturer	Radiall	
	iseg part number	Z592474	
G11		CABLE SIDE	
 Figure 13	part number	7310020	
	manufacturer	GES electronic	
	iseg part number	Z592516	
G21		CABLE SIDE	
 Figure 14	part number	7320020	
	manufacturer	GES electronic	
	iseg part number	Z592391	
G31		CABLE SIDE	
 Figure 15	part number	7331052	
	manufacturer	GES electronic	
	iseg part number	Z592501	

CONNECTORS - POWER SIDE		PART NUMBERS (manufacturer code / iseg accessory parts item code)	
D-SUB9 - male		CABLE SIDE	
PIN 1  Figure 16	connector manufacturer iseg part number	D SUD9 various manufacturer	female
Terminal block (AK2200)		CABLE SIDE	
 Figure 17	connector manufacturer iseg part number	wire / strand various manufacturer	Wire sizes (flexible) max 2.5mm ²
H15		CABLE SIDE	
 Figure 18	connector manufacturer iseg part number	Female power plug type H15, compatible with iseg crates various manufacturer	

Table 14: Connectors and PIN assignments

7 Order guides

CONFIGURATION ORDER GUIDE (item code parts)									
Ex	030	206	P	24	25	000	02	0	0
High Voltage Distinct Source	V_{nom}	I_{nom} (nA)	Polarity	Input Voltage	Monitor Voltage	Option	HV Connector	Revision	Customized Version
x=P: Metal box x=K: 3U Casette x=T: for THQ	three significant digits • 100V For Example: 030 = 3000V	two significant digits + number of zeros For Example: 206 = 20mA	P = positive N = negative	two significant digits	two significant digits 1.th hex · 1V 2.th dez · 0,1V For Example: A0 = 10V	three significant characters see 2.3 Options and Order Information For Example: CLD = Capacitor Charger	00 = Cable 02 = SHV 03 = S08 06 = G11 07 = G21 08 = G31	one digit 0 = no revision For Example: A = first revision B = second revision	one digit 0 = no customization

Table 15: Configuration item code

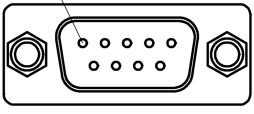
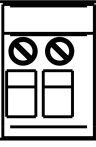
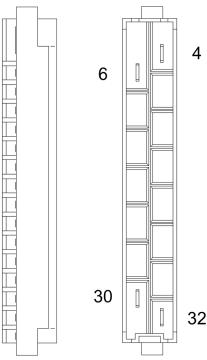
CABLE ORDER GUIDE					
POWER SUPPLY SIDE CONNECTOR	V_{max}	CABLE CODE	CABLE DESCRIPTION	LOAD SIDE CONNECTOR	ORDER CODE <i>LLL = length in m</i> ⁽¹⁾
SHV	≤ 5 kV	04	HV cable shielded 30kV (HTV-30S-22-2)	open	SHV_C04-LLL
S08	≤ 8 kV	04	HV cable shielded 30kV (HTV-30S-22-2)	open	S08_C04-LLL
G11	≤ 10 kV	02	Lemo HV cable shielded 30kV (Lemo 130660)	open	G11_C02-LLL
G21	≤ 20 kV	02	Lemo HV cable shielded 30kV (Lemo 130660)	open	G21_C02-LLL
G31	≤ 30 kV	02	Lemo HV cable shielded 30kV (Lemo 130660)	open	G31_C02-LLL

Notes:
¹⁾ Length building examples: 10cm → 0.1, 2.5m → 2.5, 12m → 012, 999m → 999

Table 16: Item code parts for different configurations

8 Appendix

For more information please use the following download links:

This document
https://iseg-hv.com/download/DC_DC/EPS/iseg_manual_EPS_en.pdf
Archive
https://iseg-hv.com/download/DC_DC/EPS/archive
Iseg crates (3UC)
https://iseg-hv.com/de/products/detail/MME_Crates
Iseg THQ
https://iseg-hv.com/de/products/detail/THQ

9 Glossary

SHORTCUT	MEANING
V_{nom}	nominal output voltage
V_{out}	output voltage
V_{set}	set value of output voltage
V_{mon}	monitor voltage of output voltage
V_{meas}	digital measured value of output voltage
V_{p-p}	peak to peak ripple voltage
V_{in}	input / supply voltage
V_{type}	type of output voltage (AC, DC)
V_{ref}	internal reference voltage
V_{max}	limit (max.) value of output voltage
$\Delta V_{out} - [\Delta V_{in}]$	deviation of V_{out} depending on variation of supply voltage
$\Delta V_{out} - [\Delta R_{load}]$	deviation of V_{out} depending on variation of output load
V_{bounds}	voltage bounds, a tolerance tube $V_{set} \pm V_{bounds}$ around V_{set}
I_{nom}	nominal output current
I_{out}	output current
I_{set}	set value of output current
I_{mon}	monitor voltage of output current
I_{meas}	digital measured value of current
I_{trip}	current limit to shut down the output voltage
I_{in}	input / supply current
I_{max}	limit (max.) value of output current
I_{limit}	current limit
I_{bounds}	current bounds, a tolerance tube $I_{set} \pm I_{bounds}$ around I_{set}
P_{nom}	nominal output power
P_{in}	input power
P_{in_nom}	nominal input power
T	temperature
T_{REF}	reference temperature
ON	HV ON
OFF	HV OFF
CH	channel(s)
HV	high voltage
LV	low voltage
GND	signal ground
INH	Inhibit
POL	Polarity
KILL	KillEnable

10 Warranty & Service

This device is made with high care and quality assurance methods. The standard factory warranty is 12 months. Please contact the iseg sales department if you wish to extend the warranty.

CAUTION!



CAUTION!

Repair and maintenance may only be performed by trained and authorized personnel.

For repair please follow the RMA instructions on our website: www.iseg-hv.com/en/support/rma

11 Disposal

INFORMATION



INFORMATION

All high-voltage equipment and integrated components are largely made of recyclable materials. Do not dispose the device with regular residual waste. Please use the recycling and disposal facilities for electrical and electronic equipment available in your country.

12 Manufacturer contact

iseg Spezialelektronik GmbH

Bautzner Landstr. 23

01454 Radeberg / OT Rossendorf

GERMANY

FON: +49 351 26996-0 | FAX: +49 351 26996-21

www.iseg-hv.com | info@iseg-hv.de | sales@iseg-hv.de